CLA-VAL

AUTOMATIC CONTROL VALVES

350-07/3650-07

Place this manual with personnel responsible
for maintenance of this valve



Installation



Operation

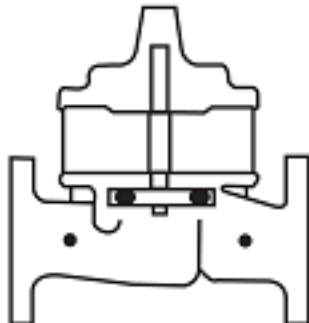

Maintenance



CLA-VAL • 1701 Placentia Avenue • Costa Mesa, CA 92627 • (949) 722-4800 • info@cla-val.com
CLA-VAL CANADA LTD. • 4687 Christie Drive • Beamsville, Ontario, LOR 1B4 Canada • (905) 563-4963

www.cla-val.com • info@cla-val.com



NEWPORT BEACH, CALIFORNIA

CATALOG NO.
350-07/3650-07

DRAWING NO.
205394

REV
B

TYPE OF VALVE AND MAIN FEATURES

ELECTRONIC INTERFACE PRESSURE SUSTAINING VALVE
WITH MANUAL HYDRAULIC BYPASS
(INTEGRAL CONTROLLER TYPE)

DESIGN		
DRAWN	AK	02-23-06
CHK'D	VL	02-27-06
APVD	CH	03-06-06

B ADDED OPTIONAL FEATURES "P" & "V", ITEM 3 WAS
CRL 32 (NED 75661)
AK
08-11-11

CAD REVISION RECORD - DO NOT REVISE MANUALLY
DESCRIPTION
BY DATE
RELEASED FOR PRODUCTION (NED 50515)
A
REVISED TITLE (ECO 20535)
AK 02-23-06
AK 06-09-06

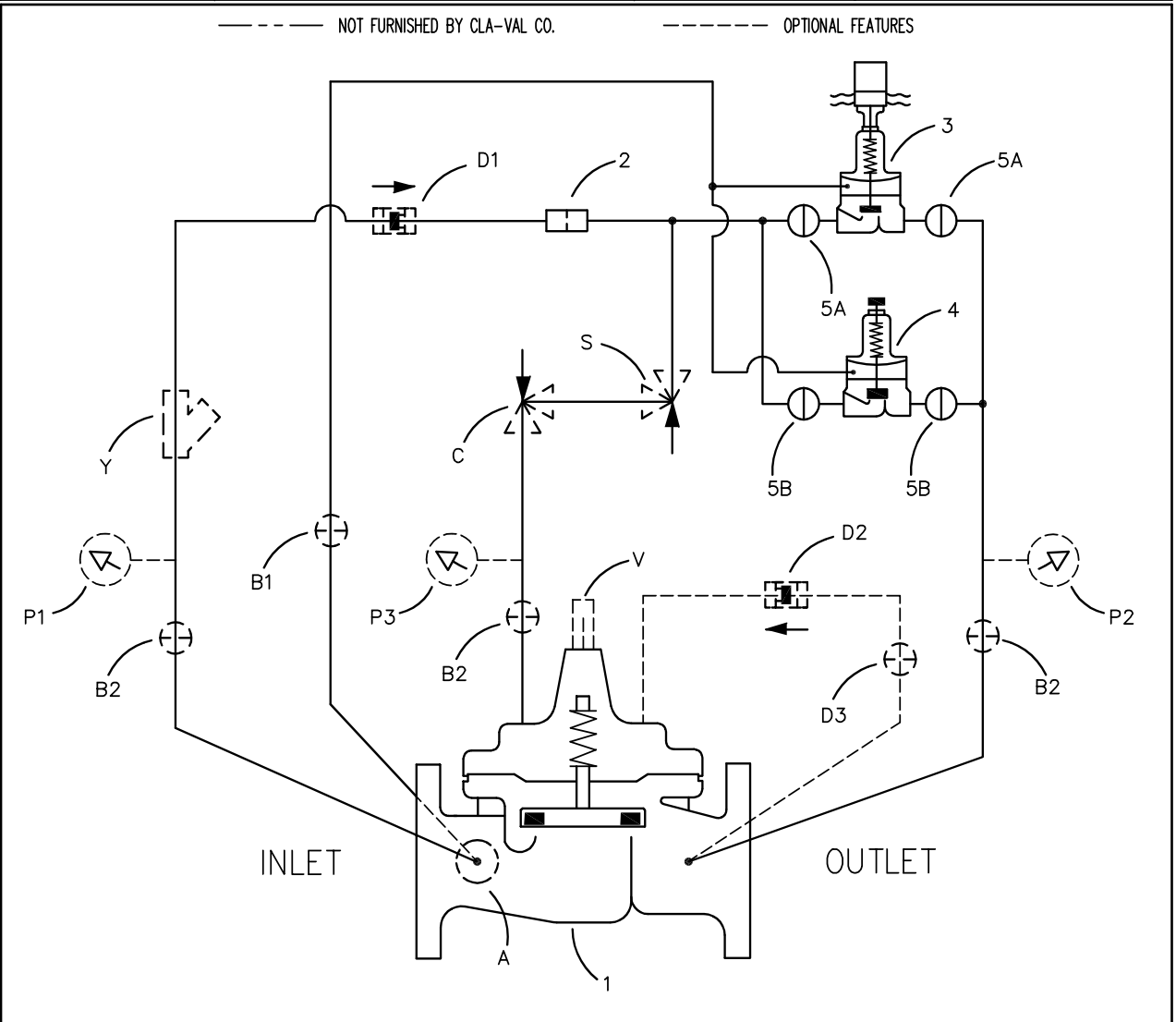

ITEM NO.	BASIC COMPONENTS	QTY
1	100-01 HYTROL (350-07) MAIN VALVE	1
	100-20 HYTROL (3650-07) MAIN VALVE	
2	X58C RESTRICTION FITTING	1
3	CRL33 ELECTRONIC PRESSURE RELIEF CONTROL	1
4	CRL5A PRESSURE RELIEF CONTROL	1
5	CK2 COCK (ISOLATION VALVE)	4

OPTIONAL FEATURE SUFFIX		ADDED TO CATALOG NUMBER	
A	X46A FLOW CLEAN STRAINER	1	
B	CK2 COCK (ISOLATION VALVE)	4	
C	CV FLOW CONTROL (CLOSING)	1	
D	CHECK VALVES WITH COCK	1	
P	X141 PRESSURE GAUGE	3	
S	CV FLOW CONTROL (OPENING)	1	
			V X101 VALVE POSITION INDICATOR 1
			Y X43 "Y" STRAINER 1

"THIS DRAWING IS THE PROPERTY OF CLA-VAL CO. AND SAME AND COPIES MADE THEREOF, IF ANY, SHALL BE RETURNED TO IT UPON DEMAND. DELIVERY AND DISCLOSURE HEREOF ARE SOLELY UPON CONDITION THAT THE SAME SHALL NOT BE USED, COPIED OR REPRODUCED, NOR SHALL THE SUBJECT HEREOF BE DISCLOSED IN ANY MANNER TO ANYONE FOR ANY PURPOSE, EXCEPT AS HEREIN AUTHORIZED, WITHOUT PRIOR WRITTEN APPROVAL OF CLA-VAL CO. THIS DRAWING IS SUBMITTED CONFIDENTIALLY AND MAY NOT BE USED IN THE MANUFACTURE OF ANY MATERIAL OR PRODUCT OTHER THAN SUCH MATERIALS AND PRODUCTS FURNISHED TO CLA-VAL CO. WHETHER OR NOT THE EQUIPMENT OR INFORMATION SHOWN HEREON IS PATENTED OR OTHERWISE PROTECTED, FULL TITLE AND COPYRIGHTS, IF ANY, IN AND TO THIS DRAWING AND/OR INFORMATION DELIVERED OR SUBMITTED ARE FULLY RESERVED CLA-VAL CO."



CLA-VAL CO.

NEWPORT BEACH, CALIFORNIA

CATALOG NO.

350-07/3650-07

DRAWING NO.

205394

REV

B

TYPE OF VALVE AND MAIN FEATURES

ELECTRONIC INTERFACE PRESSURE SUSTAINING VALVE
WITH MANUAL HYDRAULIC BYPASS
(INTEGRAL CONTROLLER TYPE)

DESIGN

DRAWN AK 02-23-06

CHK'D VL 02-27-06

APVD CH 03-06-06

OPERATING DATA

I. PRESSURE SUSTAINING FEATURE:

PRESSURE RELIEF CONTROL (3) IS A NORMALLY CLOSED CONTROL THAT RESPONDS TO MAIN VALVE INLET PRESSURE CHANGES. AN INCREASE IN INLET PRESSURE TENDS TO OPEN CONTROL (3) AND A DECREASE IN INLET PRESSURE TENDS TO CLOSE CONTROL (3). THIS CAUSES MAIN VALVE COVER PRESSURE TO VARY AND THE MAIN VALVE MODULATES (OPENS AND CLOSES) MAINTAINING A RELATIVELY CONSTANT PRESSURE AT THE MAIN VALVE INLET. WHEN INLET PRESSURE IS LOWER THAN THE SET POINT OF CONTROL (3), CONTROL (3) CLOSSES. THIS PRESSURIZES THE MAIN VALVE COVER CHAMBER AND THE MAIN VALVE CLOSSES. PRESSURE RELIEF CONTROL (3) IS EQUIPPED WITH A TWO-WAY MOTOR ACTUATOR FOR REMOTE ADJUSTMENT.

NOTE: REFER TO CLA-VAL PRINTED FORM N-CRL-33 FOR ADDITIONAL INFORMATION REGARDING INSTALLATION, OPERATION AND MAINTENANCE OF THE MOTORIZED PRESSURE RELIEF CONTROL.

II. PRESSURE SUSTAINING FEATURE:

PRESSURE RELIEF CONTROL (4) IS A NORMALLY CLOSED CONTROL THAT RESPONDS TO MAIN VALVE INLET PRESSURE CHANGES. AN INCREASE IN INLET PRESSURE TENDS TO OPEN CONTROL (4) AND A DECREASE IN INLET PRESSURE TENDS TO CLOSE CONTROL (4). THIS CAUSES MAIN VALVE COVER PRESSURE TO VARY AND THE MAIN VALVE MODULATES (OPENS AND CLOSES) MAINTAINING A RELATIVELY CONSTANT PRESSURE AT THE MAIN VALVE INLET. WHEN INLET PRESSURE IS LOWER THAN THE SET POINT OF CONTROL (4), CONTROL (4) CLOSSES. THIS PRESSURIZES THE MAIN VALVE COVER CHAMBER AND THE MAIN VALVE CLOSSES. PRESSURE RELIEF CONTROL (4) ADJUSTMENT: TURN THE ADJUSTING SCREW CLOCKWISE TO INCREASE THE SETTING.

III. MANUAL SELECTION FEATURE:

OPEN CK2 COCKS (5B) AND CLOSE (5A) TO MANUALLY SELECT PRESSURE RELIEF CONTROL (4) AND BYPASS CONTROL (3). TO PLACE THE MAIN VALVE BACK UNDER COMMAND OF PRESSURE RELIEF CONTROL (3), CLOSE CK2 COCKS (5B) AND OPEN CK2 COCKS (5A).

IV. OPTIONAL FEATURE OPERATING DATA:

SUFFIX A (FLOW CLEAN STRAINER)

A SELF-CLEANING STRAINER IS INSTALLED IN THE MAIN VALVE INLET BODY BOSS WHICH PROTECTS THE PILOT SYSTEM FROM FOREIGN PARTICLES.

SUFFIX B (ISOLATION VALVES)

CK2 COCKS (B1) & (B2) ARE USED TO ISOLATE THE PILOT SYSTEM FROM MAIN LINE PRESSURE. THESE VALVES MUST BE OPEN DURING NORMAL OPERATION.

CAD REVISION RECORD - DO NOT REVISE MANUALLY

DESCRIPTION

DATE

BY

LTR

SEE SHEET 1

 CLA-VAL CO. NEWPORT BEACH, CALIFORNIA	CATALOG NO.	DRAWING NO.	REV
	350-07/3650-07	205394	B
	TYPE OF VALVE AND MAIN FEATURES		
	ELECTRONIC INTERFACE PRESSURE SUSTAINING VALVE WITH MANUAL HYDRAULIC BYPASS (INTEGRAL CONTROLLER TYPE)		

OPERATING DATA-CONTINUED

SUFFIX C (CLOSING SPEED CONTROL)

FLOW CONTROL (C) CONTROLS THE CLOSING SPEED OF THE MAIN VALVE. TURN THE ADJUSTING STEM CLOCKWISE TO MAKE THE MAIN VALVE CLOSE SLOWER.

SUFFIX D (CHECK VALVES WITH COCK):

WHEN OUTLET PRESSURE IS HIGHER THAN INLET PRESSURE, CHECK VALVE (D2) OPENS AND (D1) CLOSSES. THIS DIRECTS THE HIGHER OUTLET PRESSURE INTO THE MAIN VALVE COVER AND THE MAIN VALVE CLOSSES.

SUFFIX P (PRESSURE GAUGE):

PRESSURE GAUGES (P) PROVIDE PRESSURE READING IN THE INLET, OUTLET AND COVER CONNECTIONS.

SUFFIX S (OPENING SPEED CONTROL)

FLOW CONTROL (S) CONTROLS THE OPENING SPEED OF THE MAIN VALVE. TURN THE ADJUSTING STEM CLOCKWISE TO MAKE THE MAIN VALVE OPEN SLOWER.

SUFFIX V (VALVE POSITION INDICATOR):

VALVE POSITION INDICATOR (V) DISPLAYS A VISUAL POSITION OF THE MAIN VALVE STEM.

SUFFIX Y (Y-STRAINER)

A Y-PATTERN STRAINER IS INSTALLED IN THE PILOT SUPPLY LINE TO PROTECT THE PILOT SYSTEM FROM FOREIGN PARTICLES. THE STRAINER SCREEN MUST BE CLEANED PERIODICALLY.

V. CHECK LIST FOR PROPER OPERATION:

- () SYSTEM VALVES OPEN UPSTREAM AND DOWNSTREAM.
- () AIR REMOVED FROM THE MAIN VALVE COVER AND PILOT SYSTEM AT ALL HIGH POINTS.
- () CK2 COCKS (B1) & (B2) OPEN (OPTIONAL FEATURE).
- () PERIODIC CLEANING OF STRAINER (Y) IS RECOMMENDED (OPTIONAL FEATURE).
- () CV FLOW (C) AND (S) OPEN AT LEAST 4 TURNS (OPTIONAL FEATURE).
- () CORRECT VOLTAGE TO ELECTRONIC PRESSURE RELIEF CONTROL (3).
- () CK2 COCKS (5A) OPEN DURING NORMAL OPERATION.
- () CK2 COCKS (5B) CLOSED DURING NORMAL OPERATION.

CAD REVISION RECORD - DO NOT REVISE MANUALLY	DATE	
	BY	
DESCRIPTION	SEE SHEET 1	
	LTR	



—MODEL— **100-01**
Hytrol Valve

Description

The Cla-Val Model 100-01 Hytrol Valve is a main valve for Cla-Val Automatic Control Valves. It is a hydraulically operated, diaphragm-actuated, globe or angle pattern valve.

This valve consists of three major components; body, diaphragm assembly, and cover. The diaphragm assembly is the only moving part. The diaphragm assembly uses a diaphragm of nylon fabric bonded with synthetic rubber. A synthetic rubber disc, contained on three and one half sides by a disc retainer and disc guide, forms a seal with the valve seat when pressure is applied above the diaphragm. The diaphragm assembly forms a sealed chamber in the upper portion of the valve, separating operating pressure from line pressure.

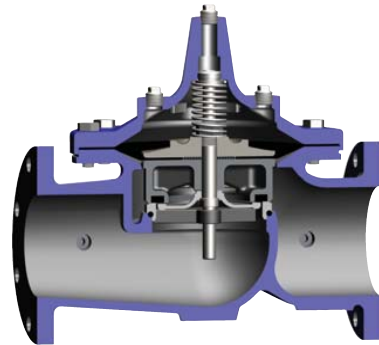

Installation

1. Before valve is installed, pipe lines should be flushed of all chips, scale and foreign matter.
2. It is recommended that either gate or block valves be installed on both ends of the 100-01 Hytrol Valve to facilitate isolating the valve for preventive maintenance and repairs.
3. Place the valve in the line with flow through the valve in the direction indicated on the inlet nameplate. (See "Flow Direction" Section)
Note: Valve can be installed in the vertical or horizontal position.
4. Allow sufficient room around valve to make adjustments and for disassembly.
5. Cla-Val 100-01 Hytrol Valves operate with maximum efficiency when mounted in horizontal piping with the cover UP, however, other positions are acceptable. Due to size and weight of the cover and internal components of 8 inch and larger valves, installation with the cover UP is advisable. This makes internal parts readily accessible for periodic inspection.

6. Caution must be taken in the installation of this valve to insure that galvanic and/or electrolytic action does not take place. The proper use of dielectric fittings and gaskets are required in all systems using dissimilar metals.
7. If a pilot control system is installed on the 100-01 Hytrol Valve, use care to prevent damage. If it is necessary to remove fittings or components, be sure they are kept clean and replaced exactly as they were.
8. After the valve is installed and the system is first pressurized, vent air from the cover chamber and pilot system tubing by loosening fittings at all high points.

Principles of Operation

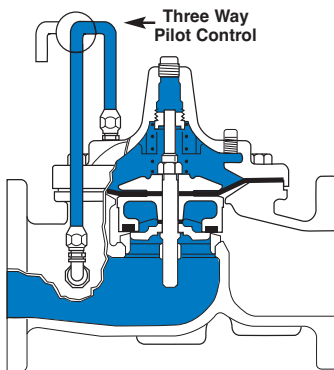

Tight Closing Operation

When pressure from the valve inlet (or an equivalent independent operating pressure) is applied to the diaphragm chamber the valve closes drip-tight.

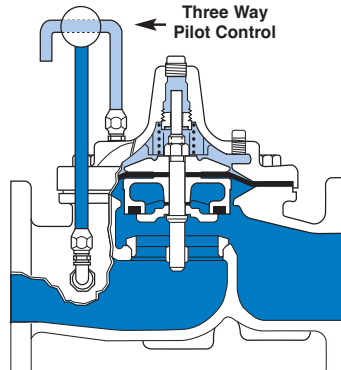

Full Open Operation

When pressure in diaphragm chamber is relieved to a zone of lower pressure (usually atmosphere) the line pressure (5 psi Min.) at the valve inlet opens the valve.

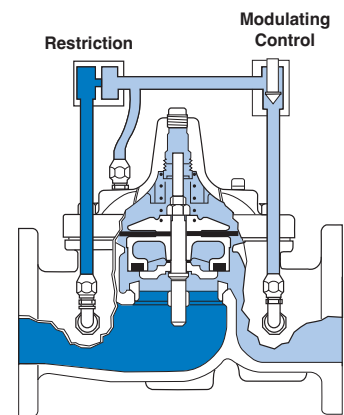

Modulating Action

Valve modulates when diaphragm pressure is held at an intermediate point between inlet and discharge pressure. With the use of a Cla-Val. "modulating control," which reacts to line pressure changes, the pressure above the diaphragm is varied, allowing the valve to throttle and compensate for the change.

Flow Direction

The flow through the 100-01 Hytrol Valve can be in one of two directions. When flow is “up-and-over the seat,” it is in “normal” flow and the valve will fail in the open position. When flow is “over-the seat-and down,” it is in “reverse” flow and the valve will fail in the closed position. There are no permanent flow arrow markings.



Recommended Tools

1. Three pressure gauges with ranges suitable to the installation to be put at Hytrol inlet, outlet and cover connections.
2. Cla-Val Model X101 Valve Position Indicator. This provides visual indication of valve position without disassembly of valve.
3. Other items are: suitable hand tools such as screwdrivers, wrenches, etc. soft jawed (brass or aluminum) vise, 400 grit wet or dry sandpaper and water for cleaning.

Troubleshooting

The following troubleshooting information deals strictly with the Model 100-01 Hytrol Valve. This assumes that all other components of the pilot control system have been checked out and are in proper working condition. (See appropriate sections in Technical Manual for complete valve).

All trouble shooting is possible without removing the valve from the line or removing the cover. It is highly recommended to permanently install a Model X101 Valve Position Indicator and three gauges in unused Hytrol inlet, outlet and cover connections.

SYMPTOM	PROBABLE CAUSE	REMEDY
Fails to Close	Closed isolation valves in control system, or in main line.	Open Isolation valves.
	Lack of cover chamber pressure.	Check upstream pressure, pilot system, strainer, tubing, valves, or needle valves for obstruction.
	Diaphragm damaged. (See Diaphragm Check.)	Replace diaphragm.
	Diaphragm assembly inoperative. Corrosion or excessive scale build up on valve stem. (See Freedom of Movement Check)	Clean and polish stem. Inspect and replace any damaged or badly eroded part.
	Mechanical obstruction. Object lodged in valve. (See Freedom of Movement Check)	Remove obstruction.
	Worn disc. (See Tight Sealing Check)	Replace disc.
	Badly scored seat. (See Tight Sealing Check)	Replace seat.
Fails to Open	Closed upstream and/or downstream isolation valves in main line.	Open isolation valves.
	Insufficient line pressure.	Check upstream pressure. (Minimum 5 psi flowing line pressure differential.)
	Diaphragm assembly inoperative. Corrosion or excessive buildup on valve stem. (See Freedom of Movement Check)	Clean and polish stem. Inspect and replace any damaged or badly eroded part.
	Diaphragm damaged. (For valves in "reverse flow" only)	Replace diaphragm.

After checking out probable causes and remedies, the following three checks can be used to diagnose the nature of the problem before maintenance is started. They must be done in the order shown.

Three Checks

The 100-01 Hytrol Valve has only one moving part (the diaphragm and disc assembly). So, there are only three major types of problems to be considered.

First: Valve is stuck - that is, the diaphragm assembly is not free to move through a full stroke either from open to close or vice versa.

Second: Valve is free to move and can't close because of a worn out diaphragm.

Third: Valve leaks even though it is free to move and the diaphragm isn't leaking.

CAUTION:

*Care should be taken when doing the troubleshooting checks on the 100-01 Hytrol Valve. These checks do require the valve to open fully. This will either allow a high flow rate through the valve, or the downstream pressure will quickly increase to the inlet pressure. In some cases, this can be very harmful. Where this is the case, and there are no block valves in the system to protect the downstream piping, it should be realized that **the valve cannot be serviced under pressure**. Steps should be taken to remedy this situation before proceeding any further.*

Diaphragm Check (#1)

1. Shut off pressure to the Hytrol Valve by slowly closing upstream and downstream isolation valves. **SEE CAUTION.**
2. Disconnect or close all pilot control lines to the valve cover and leave only one fitting in highest point of cover open to atmosphere.
3. With the cover vented to atmosphere, slowly open upstream isolation valve to allow some pressure into the Hytrol Valve body. Observe the open cover tapping for signs of continuous flow. It is not necessary to fully open isolating valve. Volume in cover chamber capacity chart will be displaced as valve moves to open position. Allow sufficient time for diaphragm assembly to shift positions. If there is no continuous flow, you can be quite certain the diaphragm is sound and the diaphragm assembly is tight. If the fluid appears to flow continuously this is a good reason to believe the diaphragm is either damaged or it is loose on the stem. In either case, this is sufficient cause to remove the valve cover and investigate the leakage. (See "Maintenance" Section for procedure.)

COVER CHAMBER CAPACITY

(Liquid Volume displaced when valve opens)

Valve size (inches)	Displacement	
	Gallons	Liters
1 1/4	.020	.07
1 1/2	.020	.07
2	.032	.12
2 1/2	.043	.16
3	.080	.30
4	.169	.64
6	.531	2.0
8	1.26	4.8
10	2.51	9.5
12	4.00	15.1
14	6.50	24.6
16	9.57	36.2
20	12.00	45.4
24	29.00	109.8
30	42.00	197.0
36	90.00	340.0

Freedom of Movement Check (#2)

4. Determining the Hytrol Valve's freedom of movement can be done by one of two methods.
5. For most valves it can be done after completing Diaphragm Check (Steps 1, 2, and 3). **SEE CAUTION.** At the end of step 3 the valve should be fully open.
6. If the valve has a Cla-Val X101 Position Indicator, observe the indicator to see that the valve opens wide. Mark the point of maximum opening.
7. Re-connect enough of the control system to permit the application of inlet pressure to the cover. Open pilot system cock so pressure flows from the inlet into the cover.
8. While pressure is building up in the cover, the valve should close smoothly. There is a hesitation in every Hytrol Valve closure, which can be mistaken for a mechanical bind. The stem will appear to stop moving very briefly before going to the closed position. This slight pause is caused by the diaphragm flexing at a particular point in the valve's travel and is not caused by a mechanical bind.
9. When closed, a mark should be made on the X101 Valve position indicator corresponding to the "closed" position. The distance between the two marks should be approximately the stem travel shown in chart.

STEM TRAVEL

(Fully Open to Fully Closed)

Valve Size (inches)		Travel (inches)	
Inches	MM	Inches	MM
1 1/4	32	0.4	10
1 1/2	40	0.4	10
2	50	0.6	15
2 1/2	65	0.7	18
3	80	0.8	20
4	100	1.1	28
6	150	1.7	43
8	200	2.3	58
10	250	2.8	71
12	300	3.4	86
14	350	4.0	100
16	400	4.5	114
20	500	5.6	143
24	600	6.7	165
30	800	7.5	190
36	900	8.5	216

10. If the stroke is different than that shown in stem travel chart this is a good reason to believe something is mechanically restricting the stroke of the valve at one end of its travel. If the flow does not stop through the valve when in the indicated "closed" position, the obstruction probably is between the disc and the seat. If the flow does stop, then the obstruction is more likely in the cover. In either case, the cover must be removed, and the obstruction located and removed. The stem should also be checked for scale build-up. (See "Maintenance, section for procedure.)

11. For valves 6" and smaller, the Hytrol Valve's freedom of movement check can also be done after all pressure is removed from the valve. **SEE CAUTION.** After closing inlet and outlet isolation valves and bleeding pressure from the valve, check that the cover chamber and the body are temporarily vented to atmosphere. Insert fabricated tool into threaded hole in top of valve stem, and lift the diaphragm assembly manually. Note any roughness. The diaphragm assembly should move smoothly throughout entire valve stroke. The tool is fabricated from rod that is threaded on one end to fit valve stem and has a "T" bar handle of some kind on the other end for easy gripping. (See chart in Step 4 of "Disassembly" Section.)

12. Place marks on this diaphragm assembly lifting tool when the valve is closed and when manually positioned open. The distance between the two marks should be approximately the stem travel shown in stem travel chart. If the stroke is different than that shown, there is a good reason to believe something is mechanically restricting the stroke of the valve. The cover must be removed, and the obstruction located and removed. The stem should also be checked for scale build-up. (See "Maintenance" Section for procedure.)

Tight Sealing Check (#3)

13. Test for seat leakage after completing checks #1 & #2 (Steps 1 to 12). **SEE CAUTION.** Close the isolation valve downstream of the Hytrol Valve. Apply inlet pressure to the cover of the valve, wait until it closes. Install a pressure gauge between the two closed valves using one of the two ports in the outlet side of the Hytrol. Watch the pressure gauge. If the pressure begins to climb, then either the downstream isolation valve is permitting pressure to creep back, or the Hytrol is allowing pressure to go through it. Usually the pressure at the Hytrol inlet will be higher than on the isolation valve discharge, so if the pressure goes up to the inlet pressure, you can be sure the Hytrol is leaking. Install another gauge downstream of isolating valve. If the pressure between the valves only goes up to the pressure on the isolation valve discharge, the Hytrol Valve is holding tight, and it was just the isolation valve leaking.

Maintenance

Preventative Maintenance

The Cla-Val Co. Model 100-01 Hytrol Valve requires no lubrication or packing and a minimum of maintenance. However, a periodic inspection schedule should be established to determine how the operating conditions of the system are affecting the valve. The effect of these actions must be determined by inspection.

Disassembly

Inspection or maintenance can be accomplished without removing the valve from the line. Repair kits with new diaphragm and disc are recommended to be on hand before work begins.

WARNING: Maintenance personnel can be injured and equipment damaged if disassembly is attempted with pressure in the valve. **SEE CAUTION.**

1. Close upstream and downstream isolation valves **and independent operating pressure when used** to shut off all pressure to the valve.
2. Loosen tube fittings in the pilot system to remove pressure from valve body and cover chamber. After pressure has been released from the valve, use care to remove the controls and tubing. Note and sketch position of tubing and controls for re-assembly. The schematic in front of the Technical Manual can be used as a guide when reassembling pilot system.
3. Remove cover nuts and remove cover. If the valve has been in service for any length of time, chances are the cover will have to be loosened by driving upward along the edge of the cover with a **dull cold chisel**.

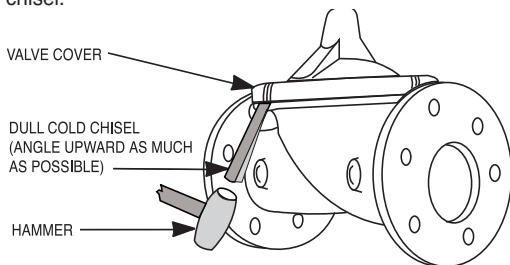

On 6" and smaller valves block and tackle or a power hoist can be used to lift valve cover by inserting proper size eye bolt in place of the center cover plug. on 8" and larger valves there are 4 holes (5/8" – 11 size) where jacking screws and/or eye bolts may be inserted for lifting purposes. **Pull cover straight up** to keep from damaging the integral seat bearing and stem.

COVER CENTER PLUG SIZE

Valve Size	Thread Size (NPT)
1 1/4" – 1 1/2"	1/4"
2" – 3"	1/2"
4" – 6"	3/4"
8" – 10"	1"
12"	1 1/4"
14"	1 1/2"
16"	2"
20" & 24"	2"
30" & 36"	2"

4. Remove the diaphragm and disc assembly from the valve body. With smaller valves this can be accomplished by hand by **pulling straight up on the stem so as not to damage the seat bearing**. On large valves, an eye bolt of proper size can be installed in the stem and the diaphragm assembly can be then lifted with a block and tackle or power hoist. Take care not to damage the stem or bearings. The valve won't work if these are damaged.

VALVE STEM THREAD SIZE

Valve Size	Thread Size (UNF Internal)
1 1/4" – 2 1/2"	10–32
3" – 4"	1/4–28
6" – 14"	3/8–24
16"	1/2–20
20	3/4–16
24"	3/4–16
30"	3/4–16
36"	3/4–16

5. The next item to remove is the stem nut. Examine the stem threads above the nut for signs of mineral deposits or corrosion. If the threads are not clean, use a wire brush to remove as much of the residue as possible. Attach a good fitting wrench to the nut and give it a sharp "rap" rather than a steady pull. Usually several blows are sufficient to loosen the nut for further removal. On the smaller valves, the entire diaphragm assembly can be held by the stem in a vise **equipped with soft brass jaws** before removing the stem nut.

The use of a pipe wrench or a vise without soft brass jaws scars the fine finish on the stem. No amount of careful dressing can restore the stem to its original condition. Damage to the finish of the stem can cause the stem to bind in the bearings and the valve will not open or close.

6. After the stem nut has been removed, the diaphragm assembly breaks down into its component parts. Removal of the disc from the disc retainer can be a problem if the valve has been in service for a long time. Using two screwdrivers inserted along the outside edge of the disc usually will accomplish its removal. Care should be taken to preserve the spacer washers in water, particularly if no new ones are available for re-assembly.

7. The only part left in the valve body is the seat which ordinarily does not require removal. Careful cleaning and polishing of inside and outside surfaces with 400 wet/dry sandpaper will usually restore the seat's sharp edge. If, however, it is badly worn and replacement is necessary, it can be easily removed.

Seats in valve sizes 1 1/4" through 6" are threaded into the valve body. They can be removed with accessory X109 Seat Removing Tool available from the factory. On 8" and larger valves, the seat is held in place by flat head machine screws. Use a tight-fitting, long shank screwdriver to prevent damage to seat screws. If upon removal of the screws the seat cannot be lifted out, it will be necessary to use a piece of angle or channel iron with a hole drilled in the center. Place it across the body so a long stud can be inserted through the center hole in the seat and the hole in the angle iron. By tightening the nut a uniform upward force is exerted on the seat for removal.

NOTE: Do not lift up on the end of the angle iron as this may force the integral bearing out of alignment, causing the stem to bind.

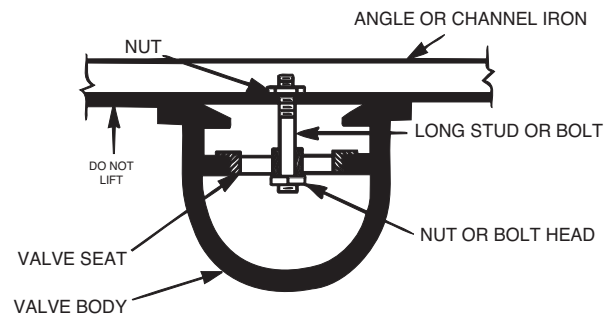

Lime Deposits

One of the easiest ways to remove lime deposits from the valve stem or other metal parts is to dip them in a 5-percent muriatic acid solution just long enough for the deposit to dissolve. This will remove most of the common types of deposits. **CAUTION: USE EXTREME CARE WHEN HANDLING ACID.** Rinse parts in water before handling. If the deposit is not removed by acid, then a fine grit (400) wet or dry sandpaper can be used with water.

Reassembly

1. Reassembly is the reverse of the disassembly procedure. If a new disc has been installed, it may require a different number of spacer washers to obtain the right amount of “grip” on the disc. When the diaphragm assembly has been tightened to a point where the diaphragm cannot be twisted, the disc should be compressed very slightly by the disc guide. Excessive compression should be avoided. Use just enough spacer washers to hold the disc firmly without noticeable compression.

2. MAKE SURE THE STEM NUT IS VERY TIGHT. Attach a good fitting wrench to the nut and give it a sharp “rap” rather than a steady pull. Usually several blows are sufficient to tighten the stem nut for final tightening. Failure to do so could allow the diaphragm to pull loose and tear when subjected to pressure.

Inspection of Parts

After the valve has been disassembled, each part should be examined carefully for signs of wear, corrosion, or any other abnormal condition. Usually, it is a good idea to replace the rubber parts (diaphragm and disc) unless they are free of signs of wear. These are available in a repair kit. Any other parts which appear doubtful should be replaced. **WHEN ORDERING PARTS, BE SURE TO GIVE COMPLETE NAMEPLATE DATA, ITEM NUMBER AND DESCRIPTION.**

NOTE: If a new disc isn't available, the existing disc can be turned over, exposing the unused surface for contact with the seat. The disc should be replaced as soon as practical.

3. Carefully install the diaphragm assembly by lowering the stem through the seat bearing. Take care not to damage the stem or bearing. Line up the diaphragm holes with the stud or bolt holes on the body. on larger valves with studs, it may be necessary to hold the diaphragm assembly up part way while putting the diaphragm over the studs.

4. Put spring in place and replace cover. Make sure diaphragm is lying smooth under the cover.

5. Tighten cover nuts firmly using a cross-over pattern until all nuts are tight.

6. Test Hytrol Valve before re-installing pilot valve system.

Test Procedure After Valve Assembly

There are a few simple tests which can be made in the field to make sure the Hytrol Valve has been assembled properly. Do these before installing pilot system and returning valve to service. These are similar to the three troubleshooting tests.

1. Check the diaphragm assembly for freedom of movement after all pressure is removed from the valve. **SEE CAUTION.** Insert fabricated tool into threaded hole in top of valve stem, and lift the diaphragm assembly manually. Note any roughness, sticking or grabbing. The diaphragm assembly should move smoothly throughout entire valve stroke. The tool is fabricated from rod that is threaded on one end to fit valve stem (See chart in Step 4 of “Disassembly” section.) and has a “T” Bar handle of some kind on the other end for easy gripping.

Place marks on this diaphragm assembly lifting tool when the valve is closed and when manually positioned open. The distance between the two marks should be approximately the stem travel shown in stem travel chart. (See “Freedom of Movement Check” section.) If the stroke is different than that shown, there is a good reason to believe something is mechanically restricting the stroke of the valve. The cover must be removed, the obstruction located and removed. (See “Maintenance” Section for procedure.)

Due to the weight of the diaphragm assembly this procedure is not possible on valves 8” and larger. on these valves, the same determination can be made by carefully introducing a low pressure-less than five psi) into the valve body with the cover vented. **SEE CAUTION.** Looking in cover center hole see the diaphragm assembly lift easily without hesitation, and then settle back easily when the pressure is removed.

2. To check the valve for drip-tight closure, a line should be connected from the inlet to the cover, and pressure applied at the inlet of the valve. If properly assembled, the valve should hold tight with as low as ten PSI at the inlet. See “Tight Sealing Check” section.)

3. With the line connected from the inlet to the cover, apply full working pressure to the inlet. Check all around the cover for any leaks. Re-tighten cover nuts if necessary to stop leaks past the diaphragm.

4. Remove pressure, then re-install the pilot system and tubing exactly as it was prior to removal. **Bleed air from all high points.**

5. Follow steps under “Start-Up and Adjustment” Section in Technical Manual for returning complete valve back to service.

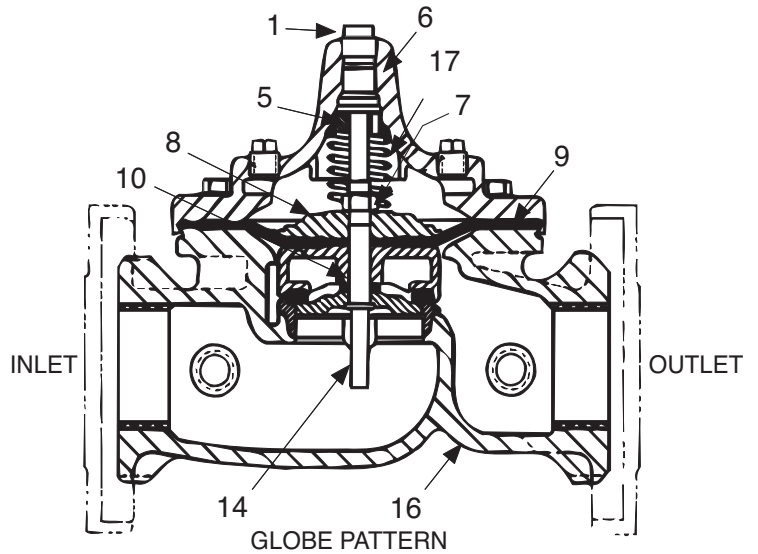
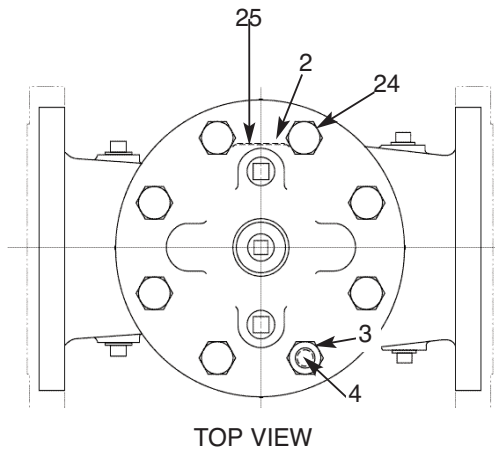

PARTS LIST

Item	Description
1.	Pipe Plug
2.	Drive Screws (for nameplate)
3.	Hex Nut (8" and larger)
4.	Stud (8" and larger)
5.	Cover Bearing
6.	Cover
7.	Stem Nut
8.	Diaphragm Washer
9.	Diaphragm
10.	Spacer Washers
11.	Disc Guide
12.	Disc Retainer
13.	Disc
14.	Stem
15.	Seat
16.	Body
17.	Spring
22.	Flat Head Screws (8" and larger)
23.	Seat O-Ring
24.	Hex head Bolt (1 1/4" thru 4")
25.	Nameplate
26.	Upper Spring Washer (Epoxy coated valves only)
27.	Lower Spring Washer (Epoxy coated valves only)
28.	Cover Bearing Housing (16" only)
29.	Cover O-Ring (16" only)
30.	Hex Bolt (16" only)
31.	Pipe Cap (16" only)

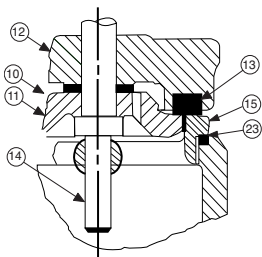
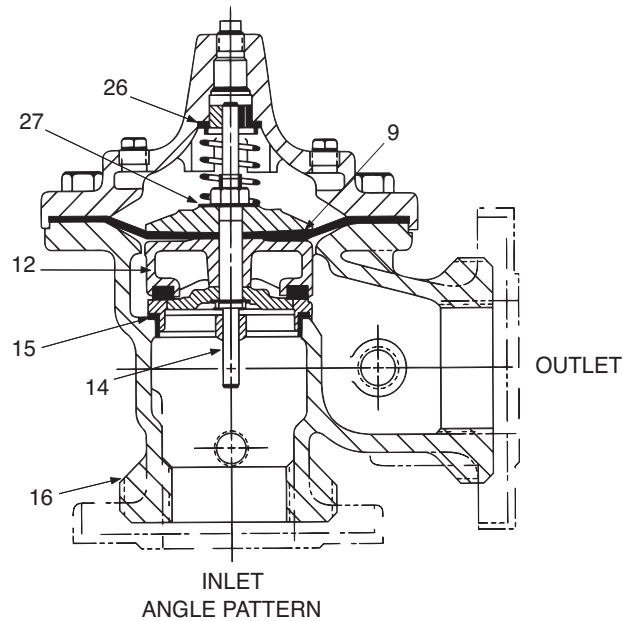

1 1/4" - 6" SEAT DETAIL

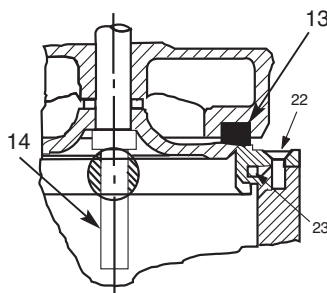

8" - 24" SEAT DETAIL

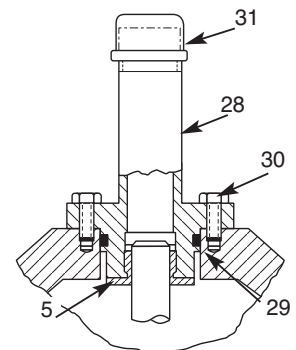

16" COVER DETAIL



—MODEL—100-01 Hytrol Valve Service Data

Description 100-01 Hytrol Valve

The Cla-Val Model 100-01 Hytrol Valve is a main valve for Cla-Val Automatic Control Valves. It is a hydraulically operated, diaphragm-actuated, globe or angle pattern valve.

This valve consists of three major components; body, diaphragm assembly, and cover. The diaphragm assembly is the only moving part. The diaphragm assembly uses a diaphragm of nylon fabric bonded with synthetic rubber. A synthetic rubber disc, contained on three and one half sides by a disc retainer and disc guide, forms a seal with the valve seat when pressure is applied above the diaphragm. The diaphragm assembly forms a sealed chamber in the upper portion of the valve, separating operating pressure from line pressure.

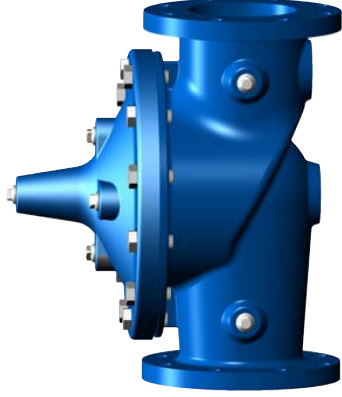

Description 100-20 600 Series Hytrol Valve

The Cla-Val Model 100-20 Hytrol Valve (600 Series main valve) have only one part -the body- that is different from standard 100 Series Cla-Val main valve parts. The remaining parts of the 600 series main valve are standard Cla-Val main valve parts. All service and maintenance information for the standard 100 Series main valves also apply to the 600 series main valves.

The most important thing to remember when ordering main valve repair kits and replacement parts, except for the body, all other parts are going to be for a smaller size main valve. Cla-Val identifies main valve parts with the flange size of the standard 100 Series main valve. Refer to the "Main Valve Sizes" chart below.

HYTROL Service Data

HYTROL SIZE		Stem Travel		Cover Capacity Displacement		Valve Stem Thread	Cover Center Plug	Cover Nut or Bolt			Cover Lifting Holes	Cover Plug		Cover Torque		Stem Nut**		Stem Nut Torque	
100-01	100-20	inches	mm	inches	mm	UNF-Internal	NPT	Thread (Bolt)	Socket	Qty	UNC	Thread	Socket	ft. Lbs.	in. Lbs.	Thread	Socket (Long)	Lubed	DRY
1"	25			0.3	8		1/4"	1/4" - 20 (B)	7/16"	8				4	48	3/8" - 24		4	6
1 1/4"	32			0.4	10	10 - 32	1/4"	5/16" - 18 (B)	1/2"	8				8	96	7/16" - 20		6	10
1 1/2"	40			0.4	10	10 - 32	1/4"	5/16" - 18 (B)	1/2"	8				8	96	7/16" - 20		6	10
2"	50			0.6	15	10 - 32	1/2"	3/8" - 16 (B)	9/16"	8		3/8"	7/16"	12	12	1/2" - 20	3/4"	10	15
2 1/2"	65			0.7	18	10 - 32	1/2"	7/16" - 14 (B)	5/8"	8		1/2"	9/16"	20	20	5/8" - 18	15/16"	21	30
3"	80	4"	100	0.8	20	1/4 - 28	1/2"	1/2" - 13 (B)	3/4"	8		1/2"	9/16"	30	30	5/8" - 18	15/16"	21	30
4"	100	6"	150	1.1	23	1/4 - 28	3/4"	3/4" - 10 (B)	1 1/8"	8		3/4"	5/8"	110	110	3/4" - 16	1 1/16"	40	60
6"	150	8"	200	1.7	43	3/8 - 24	3/4"	3/4" - 10 (B)	1 1/8"	12		3/4"	5/8"	110	110	7/8" - 14	1 5/16"	85	125
8"	200	10"	250	2.3	58	3/8 - 24	1"	3/4" - 10	1 1/4"	16	5/8" - 11	1"	13/16"	110	110	1 1/8" - 12	1 13/16"	125	185
10"	250	12"	300	2.8	71	3/8 - 24	1"	7/8" - 9	1 7/16"	20	3/4" - 10	1"	13/16"	160	160	1 1/2" - 12	1 7/8"	252	375
12"	300	16"	400	3.4	86	3/8 - 24	1 1/4"	1 1/8" - 7	1 13/16"	20	3/4" - 10	1"	13/16"	390	390	1 1/2" - 12	2 1/2"	270	400
14"	350			3.9	99	3/8 - 24	1 1/2"	1 1/4" - 7	2"	20	1" - 8	1"	13/16"	545	545	1 1/2" - 12	2 1/2"	280	420
16"	400	20", 24"	600	4.5	114	1/2 - 20	2"	1 1/4" - 7	2"	20	1" - 8	1"	13/16"	545	545	2" - 16	3"	500	750
20"	500			5.63	143	3/4 - 16	1 1/2"	1 3/8" - 6	2 1/8"	24	1" - 8	1"	13/16"	670	670	2 1/4" - 16	3 1/2"	930	N/R
24"	600	30"	800	6.75	165	3/4 - 16*	3/4"	1 1/2" - 12	2 3/8"	24	1 1/8" - 7	1"	13/16"	800	800	3" - 12	Special	1350	N/R

* Adapter p/n 2594101E inside 1/4" - 28"

Grade 5 Bolts
"Heavy" Grade Nuts
Tighten cover nuts in a "star" cross-over pattern

** Must Use ONLY Cla-Val Supplied part

BOLT/NUT TORQUING PROCEDURES ON VALVE COVERS

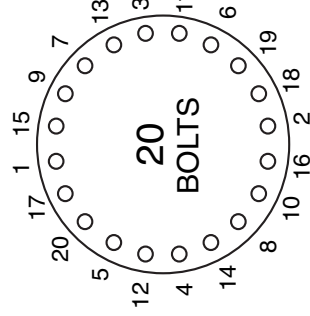
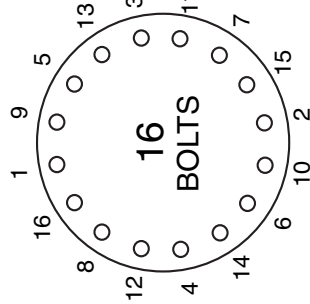
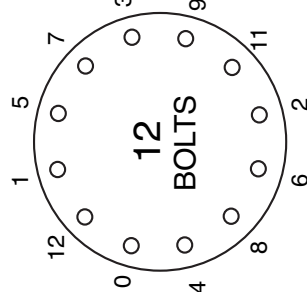
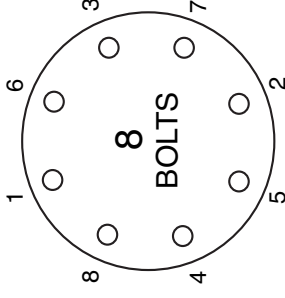
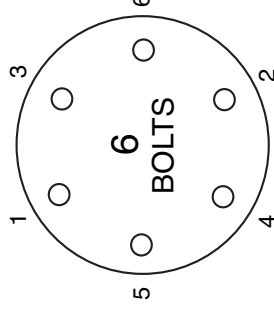
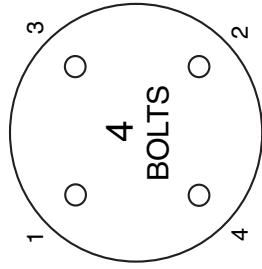

Follow this procedure when reassembling MAIN Valve:

1. Tightens bolts/nuts in a "Star" or "Cross-Over" pattern following the numbers shown above to insure that cover seats evenly on the diaphragm material and body.
2. Torque the bolt/nuts in three stages with a "Star" or "Cross-Over" pattern for each stage:
 - A. To approximately 10% of final torque.
 - B. To approximately 75% of final torque.
 - C. To final required torque.
3. Valves that are to be tested to 375 PSI or higher should be retorqued after 24 hours.

100-01 Hytrol Main Valve Assembly

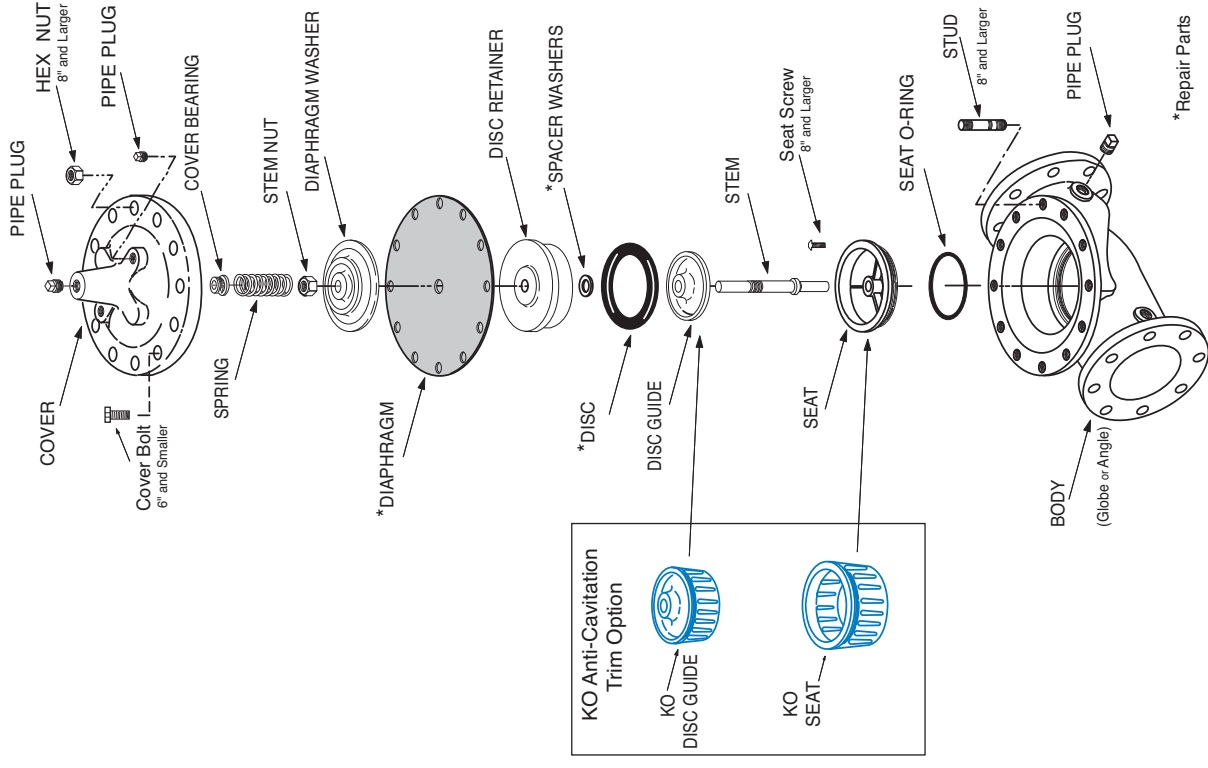

*Repair Parts



— MODEL — **100-20**
(Reduced Internal Port)

600 Series Hytrol Valve

SERVICE AND MAINTENANCE OF 600 SERIES VALVES

The 600 series main valves have only one part -the body- that is different from standard 100 Series Cla-Val main valve parts. The remaining parts of the 600 series main valve are standard Cla-Val main valve parts. All service and maintenance information for the standard 100 Series main valves in this manual also apply to the 600 series main valves.

The most important thing to remember when ordering main valve repair kits and replacement parts, except for the body, all other parts are going to be for a smaller size main valve. Cla-Val identifies main valve parts with the flange size of the standard 100 Series main valve. Refer to the "Main Valve Sizes Comparison" chart. For example, if you are servicing a 6" 100-20 Hytrol and needed a repair kit, you would order a repair kit for a 4" 100-01 Hytrol. This kit is also suitable for a 6" 100-20 Hytrol. Complete Technical Manuals include a repair kit data sheet N-RK that shows this relationship.

When you order repair parts, it is a good idea to include valve nameplate data (size, catalog number, and part number) and description of the parts desired. Do this to be sure parts will fit the valve you are working on and not be too big for it. Pilot controls and repair kits maintenance information remain the same for 100 or 600 Series valves.

UNDERSTANDING THE 600 SERIES VALVES

In 1987, Cla-Val introduced the Model 100-20 Hytrol as the basic main valve for the 600 Series of automatic control valves. To identify all new valves using the 100-20 Hytrol, an existing catalog number is modified. Making a 600 Series catalog number is simply done by using a "6" in front of the two digit catalog numbers or replacing the "2" with a "6" in three digit catalog numbers. Current schematics reflect both catalog numbers together separated by a slash (i.e. - 90-01/690-01, 58-02/658-02, 210-01/610-01, etc). Since these two valves 'share' the same catalog number and schematic, they provide the same function in a system. The only difference between the two valves is the relative capacity of the two main valve series.

The 100-01 Hytrol is the basic main valve for Cla-Val automatic control valves. This valve is the current version of the Clayton Hytrol valve design originated in 1936. The 100-01 Hytrol is designed as a full flow area valve. This means that the inlet, seat and outlet openings are the same size. Thus, the pressure drop is kept to a minimum for this globe style design.

The 100-20 Hytrol valve has all of the basic features and advantages of the original 100-01 Hytrol. Only one part has been changed - the body. It is designed with different size inlet, seat and outlet openings. The 100-20 Hytrol has inlet and outlet flanges one valve size larger than the seat opening size. This results in what is sometimes called a 'reduced port' main valve. For example, a 4" 100-20 valve has a 3" seat. Note: valve size is always determined by the flange size. The following chart compares the 100-01 and the 100-20 main valves.

Basic Main Valve Size Comparison		
Globe Pattern Valves		
Flange Size (inch)	Seat Size	
	100-01 (100 Series)	100-20 (600 Series)
3	3	2
4	4	3
6	6	4
8	8	6
10	10	8
12	12	10
14	14	----
16	16	12
18	----	16
20	20	16
24	24	16
30	30	24
36	36	30
42	----	36
48	----	36
Angle Pattern Valves		
Flange Size (inch)	Seat Size	
	100-01 (100 Series)	100-20 (600 Series)
4	4	3
6	6	4
8	8	6

The 100-20 Hytrol is available only in ductile iron, 150 and 300 pressure class, and Bronze trim standard. Available extra cost main valve options include stainless steel trim, epoxy coating, Dura-Kleen stem, Delrin sleeved stem, and high temperature rubber parts. All four basic main valves have a 600 Series version available with all of the same benefits and size relationships. The following chart shows the relationship of Cla-Val main valve catalog numbers.

Cla-Val Main Valves

Catalog Name	Catalog Number		
	Circa 1936	100-Series	600 Series
Hytrol	100 (Angle =2100)	100-01	100-20
Powertrol	100P & 100PA	100-02	100-21
Powercheck	100PC & 100PCA	100-03	100-22
Hycheck	181	100-04	100-23

100-20

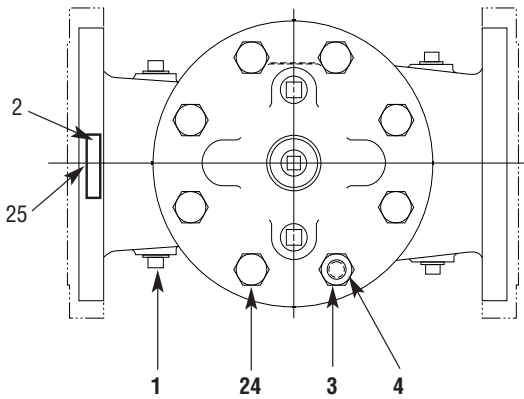

TOP VIEW

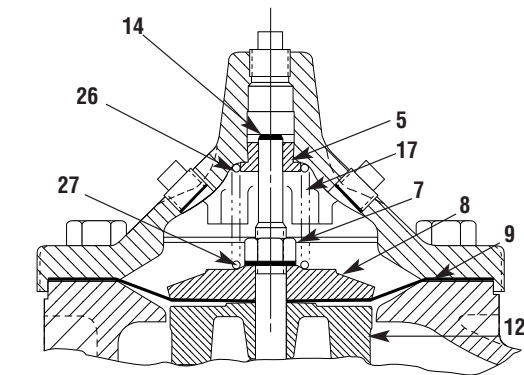
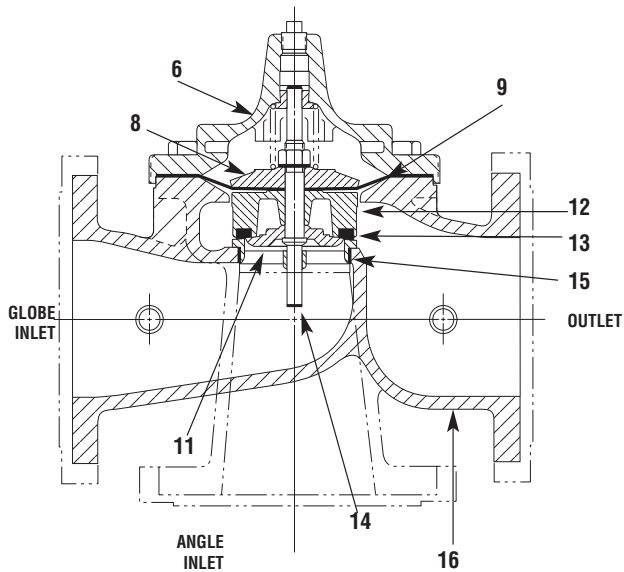

3" - 6" COVER DETAIL

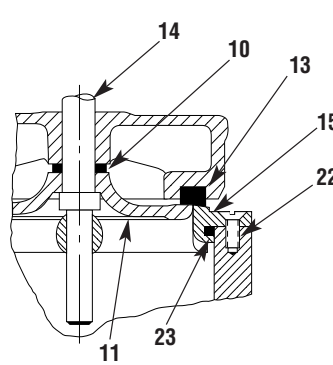

10" - 24" SEAT DETAIL

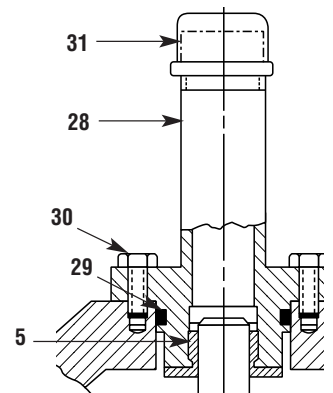

20" - 24" COVER DETAIL

PARTS LIST

NO. DESCRIPTION

- 1 Pipe Plug
- 2 Drive Screws (for nameplate)
- 3 Hex Nut (8" and larger)
- 4 Stud (8" and larger)
- 5 Cover Bearing
- 6 Cover
- 7 Stem Nut
- 8 Diaphragm Washer
- 9 Diaphragm
- 10 Spacer Washers
- 11 Disc Guide
- 12 Disc Retainer
- 13 Disc
- 14 Stem
- 15 Seat
- 16 Body
- 17 Spring
- 22 Flat Head Screws (10" and larger)
- 23 Seat O-Ring
- 24 Hex Bolt (3" Thru 6")
- 25 Nameplate (Mounted on inlet flange)
- 26 Upper Spring Washer (Epoxy coated valves only)
- 27 Lower Spring Washer (Epoxy coated valves only)
- 28 Cover Bearing Housing (20" & 24" & 30")
- 29 Cover Bearing Housing O-Ring (20" & 24" & 30")
- 30 Hex Bolt (20" & 24")
- 31 Pipe Cap (20" & 24" & 30")

WHEN ORDERING PARTS, BE SURE TO GIVE COMPLETE NAMEPLATE DATA, ITEM NUMBER AND DESCRIPTION.



Technical Bulletin



300 Series (Single-Mode) Electronic Actuated Pilot Controls

Introduction

CDB-32, CDHS-32, CRA-32, CRD-32, and CRL-32 are pilot controls for Cla-Val 300 Series Electronic Actuated Control Valves. These controls offer the same hydraulic control of the valve as existing manually-set controls, along with additional remote electronic setpoint adjustment capabilities. The new pilot controls consist of a modified pilot control sub-assembly, and the 130VC-2 Electronic Actuator with mounting components. Complete controls are valve mounted with an accessory X56 Mounting Assembly.

I. O. M. Information

A. The 130VC-2 wiring diagram is included with this technical bulletin. The 5-wire cable is permanently attached to actuator and should be terminated in suitable junction box. Care should be used when attaching to wires to avoid damage. There are no user serviceable parts inside the actuator and tampering or opening it will void the warranty.

B. For Installation, Operation and Maintenance information only on the pilot sub-assembly use instructions in the appropriate N-sheet for the manually adjusted pilot control. Since the 130VC-2 Electronic Actuator changes the setpoint adjustment of the control, all other service and maintenance information remains the same for both. See table below.

Pilot Control	Pilot Assembly Drawing	Sub-Assembly IOM (ref. only)	Sub-Assembly Drawing	Sub-Assembly Repair Kit
CDB-32	205580	N-CDB-7	201935	9170023H
CDHS-32	205137	N-CDHS-11A	76832	20287401E
CDHS-32A	205333	N-CDHS-11B	205332	9170028G
CRA-32		N-CRA	82528	9170001D
CRD-32	205129	N-CRD	70899	9170002B
CRL-32	205130	N-CRL-5A	90846	20666E

C. Additional service notes:

1. Before disassembly of pilot subassembly from 130VC-2 actuator, adjust pilot control to full minimum range setting with laptop computer and 130VC-2 software to ensure full adjustment range when reassembled.
2. Note orientation of sub-assembly ports and bracket. Coupler and blue Aluminum bracket will remain attached to actuator. Loosen and remove jam nut and washer from sub-assembly cover as sub-assembly is removed from 130VC-2 bracket. Count number of turns counterclockwise of pilot adjustment shaft from minimum range set position to full out stop position. See pilot drawing.
3. After servicing the pilot sub-assembly, re-establish minimum spring setting by manually turning adjusting screw counterclockwise until it stops (full out stop position). Then, turn in same number of turns found in step 2 to minimum range set position.
4. Do not lubricate coupler slots. A small amount of waterproof anti-seize grease is used only on sub-assembly adjusting screw threads and contact point with spring guide inside cover.
5. Reinstall sub-assembly to bracket with jam nut and washer. Check coupler slots and adjusting screw pin are lined up while installing actuator to bracket. Be sure to retain original alignment of sub-assembly with bracket when tightening jam nut and washer. A slight manual adjustment of adjusting screw may help align the coupler to adjusting screw. See pilot assembly drawing.
6. After reinstalling onto valve, use laptop computer and 130VC-2 software to reset range values.



—MODELS— **CRL-32**

Electronic Actuated Pressure Sustaining Pilot Control

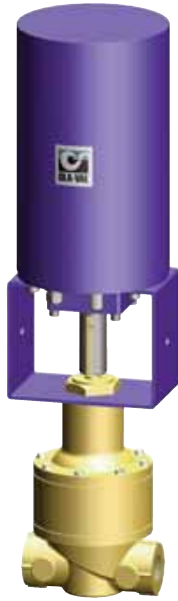

- Simplified Remote Valve Set-Point Control
- 12-24VDC Input Power
- Easy Interfacing to SCADA Systems
- Accurate Pressure Control
- Reliable Hydraulic Operation
- Submersible (IP-68)

The Cla-Val Model CRL-32 Electronic Actuated Pressure Sustaining Pilot Control provides remote set-point adjustment and accurate pressure sustaining control on Cla-Val 350 Series Control Valves. Remote set-point command signals can be from any SCADA-type control system that uses analog 4-20 mA signals. The CRL-32 senses upstream pressure with a remote hydraulic connection. Operating on 12 to 24 VDC and consuming very little power, it is an ideal control system for remote valve sites that may even be solar powered. Existing manually-set Cla-Val 50 Series Pressure Sustaining control valves can be retrofitted with CRL-32 to add remote set-point control of minimum inlet pressure. Verification of inlet pressure may be sent to SCADA system from customer supplied pressure sensor attached upstream of valve.

The CRL-32 consists of a hydraulic pilot and integral controller that accepts a 4-20 mA remote set-point and positions the pilot to maintain a minimum pressure at valve inlet within preset limits. Pressure settings are linear between these settings. Special USB connector cable and free downloadable software is required to change built-in electronic range limits for upstream sustained pressure. Continuous internal monitoring of actuator position results in smooth transitions between pilot set-points with no backlash or dithering. When power or control input fail, the CRL-32 pilot remains in automatic hydraulic control assuring system stability under all conditions.

Typical Applications

The CRL-32 is installed on Cla-Val 350 Series valves that maintain minimum upstream pressure by relieving excess pressure to lower zone and require this pressure setting to be changed from a remote location. It is also an effective solution for lowering costs associated with "confined space" requirements by eliminating the need for entry in valve structure for set point adjustment. Additional pilot controls, hydraulic and/or electronic, are also available to perform multiple functions to fit exact system requirements.

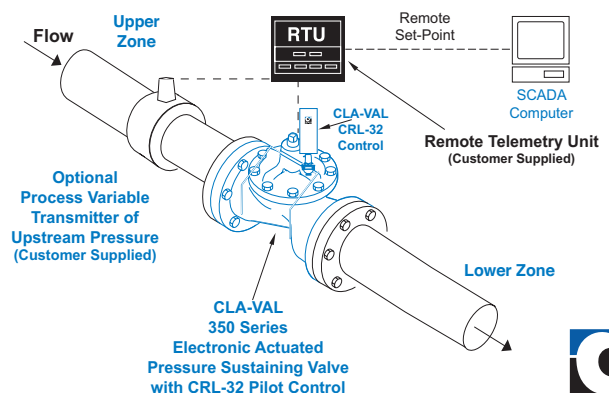
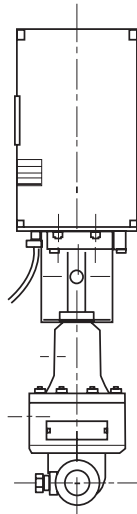
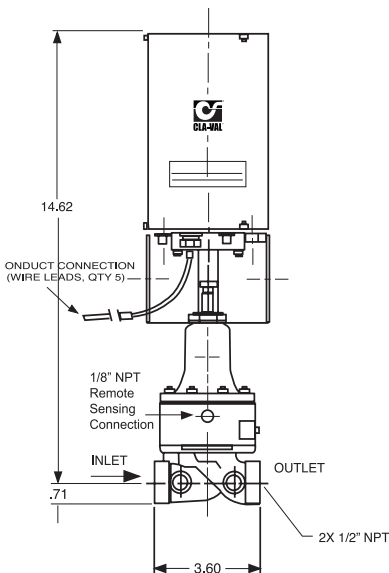

CRL-32 Purchase Specifications

The Electronic Actuated Pressure Sustaining Pilot Control shall have an integral hydraulic pilot and electronic controller contained in a IP-68 rated submersible enclosure to provide interface between remote telemetry and valve set-point control. It will compare a remote analog command signal with an internal position sensor signal and adjust the hydraulic pilot control spring mechanism to a new set-point position. 4-20 mA actuator position feedback output shall be supplied standard.

If power fails the valve shall continue to control to the last set-point command. If the Remote Set-Point signal is lost the actuator is programmable to go to either the 4mA, Last, or 20mA command set-point. No mechanical adjustments shall be necessary to the actuator. The low and high position range adjustment shall be accomplished only with valve manufacturer's components and instructions to be supplied in a separate kit.

The Electronic Actuated Pressure Sustaining Pilot Control shall be Cla-Val Model CRL-32 as manufactured by Cla-Val, Newport Beach, CA.

Pilot Control Subassembly Specifications

Adjustment Ranges

0 to 75 psi
20 to 200 psi

End Connection

1/2" NPT

Temperature Range

Water: to 180°F

Materials

Pilot Control: Bronze ASTM B62
Trim: Stainless Steel Type 303
Rubber: Buna-N® Synthetic Rubber

Available with optional Stainless Steel or Monel materials at additional cost. Consult factory for details.

Note: Shipping Weight: 8 Lbs.

Options:

Re-ranging software - free download from www.cla-val.com.
USB connection cable required when changing range parameters or restoring range parameters after servicing pilot control subassembly.

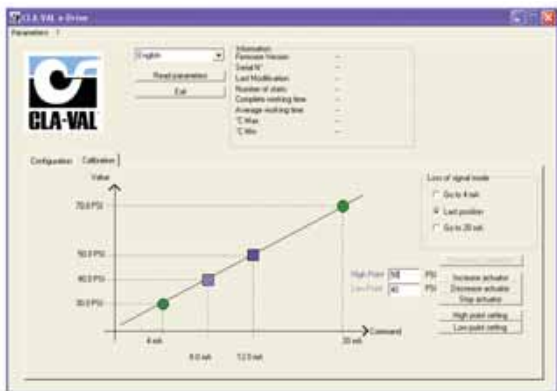

Ranging software makes it easy to set low (4mA) and high (20mA) set-point limits.

130VC-2 Electronic Actuator Specifications

Supply Power Input: 12V to 24V DC
No Load draw: 50 mA
Max. Load draw: 250 mA

Remote Command Input: 4-20 mA analog signal

Position Feedback Signal: 4-20 mA

Speed of Rotation: Adjustable On/Off time, max 6 rpm

Diagnostic: LED Indicator

Loss of Power: Actuator will remain in last commanded position.

Loss of Signal Programmable - 4mA, Last, or 20mA

Electrical Connections: Single, permanently attached cable with color-coded power supply and signal wires

Mechanical Specifications:

Environmental

Protection Class: IP-68 (Temporary submersible)
Ambient Temperature: 15° to 150° F (-10° to 65° C)

Materials

Enclosure and Bracket: Anodized Aluminum
Coupling Assembly: Stainless Steel
Gear Train: Stainless Steel, permanently lubricated

When Ordering, Please Specify

1. Catalog CRL-32
2. Adjustment Range
3. Materials - Pilot Control
4. X56 Mounting Kit (Specify Valve Size)



E-CRL-32 (R-1/08)

CLA-VAL

PO Box 1325 Newport Beach CA 92659-0325
Phone: 949-722-4800 • Fax: 949-548-5441

CLA-VAL CANADA

4687 Christie Drive
Beamsville, Ontario
Canada LOR 1B4
Phone: 905-563-4963
Fax: 905-563-4040

CLA-VAL EUROPE

Chemin des Mesanges 1
CH-1032 Romanel/
Lausanne, Switzerland
Phone: 41-21-643-15-55
Fax: 41-21-643-15-50

©COPYRIGHT CLA-VAL 2008 Printed in USA
Specifications subject to change without notice.

www.cla-val.com

Represented By:



NEWPORT BEACH, CALIFORNIA

CATALOG NO.
X58C

DRAWING NO.
48834

REV
AP

TYPE OF VALVE AND MAIN FEATURES

X58C RESTRICTION ASSEMBLIES

DESIGN		
DRAWN	JC	12-3-85
CHK'D	JC	12-4-85
APV'D	CH	12-11-85

TLC	10-18-94
AK	09-15-98
EK	9-29-11
AM	REINSTATED PN 68565B & 64673H (ECO 15043)
AN	ADDED PN 48834-05F (NED 43663)
AP	ADDED PN 48834-06D (NED 75779)

CAD REVISION RECORD - DO NOT REVISE MANUALLY	
DESCRIPTION	DATE
BY	
EK	11-18-93
AL REDRAWN ON CAD (ECO 14229)	
LTR	
A-AK	SEE REVISION FILE

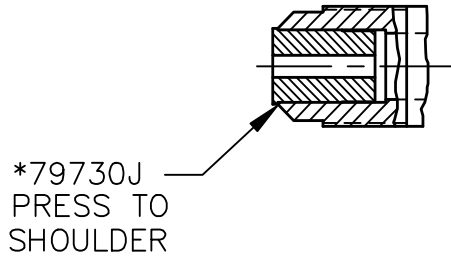
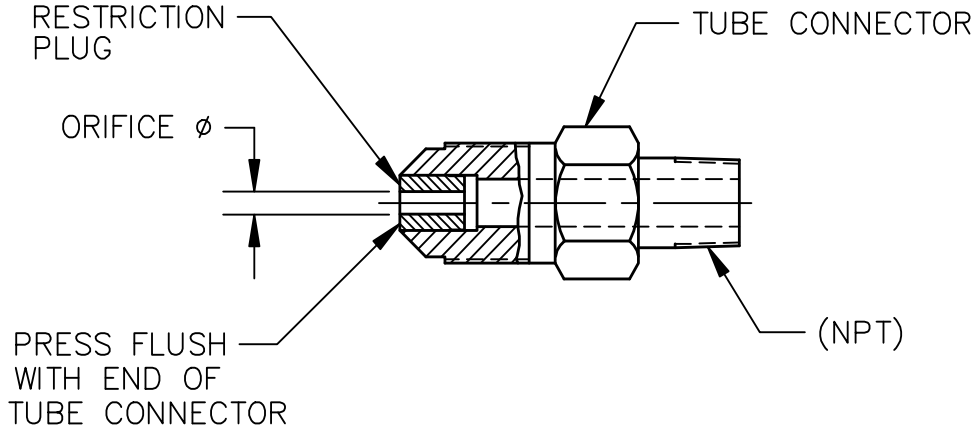

NOTES:

1. *FOR IDENTIFICATION, THESE STOCK NO'S ARE TO BE STAINED BLUE WITH 74234-03.
2. **FOR IDENTIFICATION, THESE STOCK NO'S ARE TO BE STAINED RED WITH 74234-05.
3. SEE DWG 76740 FOR STAINLESS STEEL X58C.
4. SEE SHEETS 3 & 4 FOR UL APPROVED DRAWING.



NEWPORT BEACH, CALIFORNIA

CATALOG NO.
X58C

DRAWING NO.
48834

REV
AP

TYPE OF VALVE AND MAIN FEATURES

X58C RESTRICTION ASSEMBLIES

DESIGN		
DRAWN	JC	12-3-85
CHK'D	JC	12-4-85
APV'D	CH	12-11-85

X58C STOCK NO.	TUBE CONNECTOR		RESTRICTION PLUG	
	SIZE TUBE X NPT	MATERIAL	ORIFICE DIA	MATERIAL
**44734C	3/8 X 3/8-18 NPT	ALUMINUM	.125 (1/8)	S. STEEL
	<u>37° FLARE</u>			
*37814B	1/4 X 1/8-27 NPT	BRASS	.031 (1/32)	S. STEEL
*80500C	1/4 X 1/8-27 NPT	BRASS	.062 (1/16)	S. STEEL
*67739D	3/8 X 1/8-27 NPT	BRASS	.040	S. STEEL
*64672K	3/8 X 3/8-18 NPT	BRASS	.062 (1/16)	S. STEEL
*99329-01D	3/8 X 3/8-18 NPT	BRASS	.094 (3/32)	S. STEEL
**79730J	1/2 X 1/2-14 NPT	BRASS	.125 (1/8)	S. STEEL
**48834-05F	3/8 X 3/8-18 NPT	BRASS	.125 (1/8)	S. STEEL
*85484E	1/4 X 1/8-27 NPT	BRASS	.031 (1/32)	DELTRIN
*85486K	1/4 X 1/8-27 NPT	BRASS	.040	DELTRIN
**48834-03A	1/4 X 1/8-27 NPT	BRASS	.125 (1/8)	DELTRIN
*48834-04J	1/4 X 1/8-27 NPT	BRASS	.093	DELTRIN
*88409-01G	3/8 X 1/8-27 NPT	BRASS	.031 (1/32)	DELTRIN
*88409J	3/8 X 1/8-27 NPT	BRASS	.052	DELTRIN
*42346H	3/8 X 1/8-27 NPT	BRASS	.062 (1/16)	DELTRIN
**48834-01E	3/8 X 1/8-27 NPT	BRASS	.125 (1/8)	DELTRIN
*42775H	3/8 X 1/4-18 NPT	BRASS	.062 (1/16)	DELTRIN
**63604D	3/8 X 1/4-18 NPT	BRASS	.156 (5/32)	DELTRIN
*10253D	3/8 X 3/8-18 NPT	BRASS	.031 (1/32)	DELTRIN
*46946A	3/8 X 3/8-18 NPT	BRASS	.062 (1/16)	DELTRIN
**64673H	3/8 X 3/8-18 NPT	BRASS	.125 (1/8)	DELTRIN
*68565B	3/8 X 3/8-18 NPT	BRASS	.094 (3/32)	DELTRIN
**43302K	3/8 X 3/8-18 NPT	BRASS	.188 (3/16)	DELTRIN
**12900H	1/2 X 1/2-14 NPT	BRASS	.125 (1/8)	DELTRIN
**48834-02C	1/2 X 1/2-14 NPT	BRASS	.188 (3/16)	DELTRIN
**48834-06D	1/2 X 1/2-14 NPT	BRASS	.250 (1/4)	DELTRIN

CAD REVISION RECORD - DO NOT REVISE MANUALLY

DATE

BY

DESCRIPTION

SEE SHEET 1

LTR

THIS DRAWING IS THE PROPERTY OF CLA-VAL CO. AND SAME AND COPIES MADE THEREOF, IF ANY, SHALL BE RETURNED TO IT UPON DEMAND. DELIVERY AND DISCLOSURE HEREOF ARE SOLELY UPON CONDITION THAT THE SAME SHALL NOT BE USED, COPIED OR REPRODUCED, NOR SHALL THE SUBJECT HEREOF BE DISCLOSED IN ANY MANNER TO ANYONE FOR ANY PURPOSE, EXCEPT AS HEREIN AUTHORIZED, WITHOUT PRIOR WRITTEN APPROVAL OF CLA-VAL CO. THIS DRAWING IS SUBMITTED CONFIDENTIALLY AND MAY NOT BE USED IN THE MANUFACTURE OF ANY MATERIAL OR PRODUCT OTHER THAN SUCH MATERIALS AND PRODUCTS FURNISHED TO CLA-VAL CO. WHETHER OR NOT THE EQUIPMENT OR INFORMATION SHOWN HEREON IS PATENTED OR OTHERWISE PROTECTED, FULL TITLE AND COPYRIGHTS, IF ANY, IN AND TO THIS DRAWING AND/OR INFORMATION DELIVERED OR SUBMITTED ARE FULLY RESERVED CLA-VAL CO.

The design & the weight of this valve are subject to change without notice and without obligation of notification. The user of this valve shall be responsible for determining the correct pressure and temperature ratings for the intended application. The user shall also be responsible for determining the correct installation and operating procedures. The user shall also be responsible for determining the correct maintenance and repair procedures. The user shall also be responsible for determining the correct storage and handling procedures. The user shall also be responsible for determining the correct disposal procedures.

TRUE LOCATION OF SENSING CONNECTION

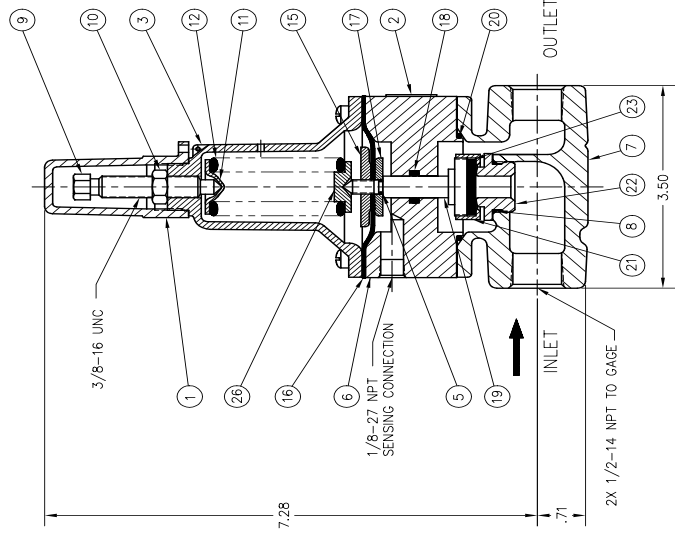
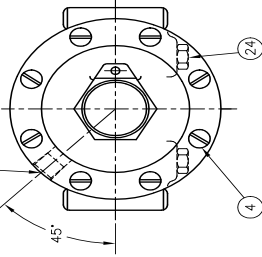

0-75, 5-25, 20-105 & 20-200 PSI
LOW PRESSURE DESIGN

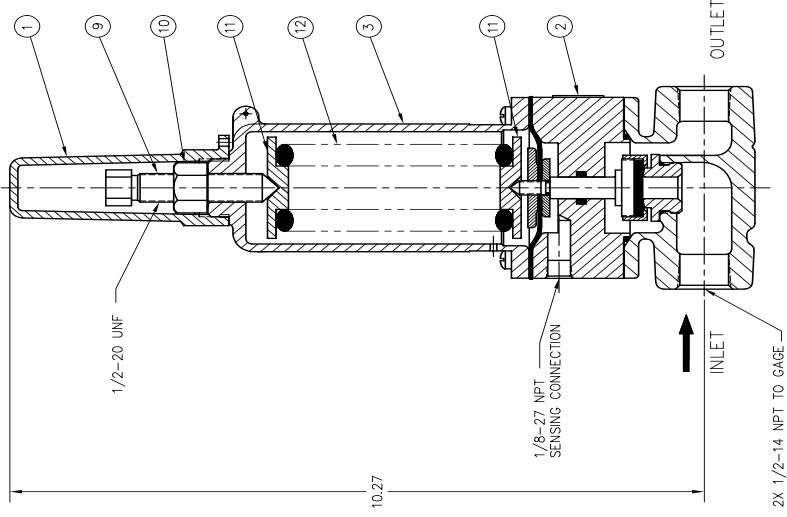

100-300 PSI
HIGH PRESSURE DESIGN

CRL5A RANGE PSI	APPROXIMATE INCREASE FOR EACH CLOCKWISE TURN OF ADJUSTING SCREW, ITEM NO. 9
0-75	8.5 PSI
5-25	4.0 PSI
20-105	13.0 PSI
20-200	28.0 PSI
100-300	19.0 PSI

* = RECOMMENDED SPARE PARTS

ITEM NO.	DESCRIPTION	QTY
26	GUIDE, SPRING, LOWER (FOR LOW PRESSURE DESIGN ONLY)	1
25	-58EW-FE-HD-10-32-2-1/4-LG-H68-560-PSI-ONE-P-2	2
24	PLUG, PIPE	2
23	DISC ASSEMBLY	1
22	SEAT	1
21	RETAINER, DISC	1
20	O-RING	1
19	STEM	1
18	O-RING	1
17	WASHER, DIAPHRAGM, LOWER	1
16	DIAPHRAGM	1
15	WASHER, DIAPHRAGM, UPPER	1
14		
13	SPRING	1
12	GUIDE, SPRING	A/R
11	NUT, JAM	1
10	SCREW, ADJUSTING	1
9	BODY, POWERUNIT	1
8	COVER	1
7	NAMEPLATE	1
6	SCREW, FIL. HD 10-32 X 1.88 LG	8
5	SCREW, FIL. HD 10-32 X 1.88 LG	8
4	COVER	1
3	COVER	1
2	NAMEPLATE	1
1	CAP	1

UNLESS OTHERWISE SPECIFIED
DIMENSIONS ARE IN INCHES
DECIMALS
FRACTIONS
ANGULAR
± 1/32" MAX
± .015" MAX
± .015" MAX
MAX = +.00 - .09
MIN = -.09 - .00
SURFACE FINISH 1/4"
BREAK CORNERS .010 MAX
--DO NOT SCALE DRAWING--

CONTRACT NO.	TITLE
---	CL5A VAL 60
---	NEWPORT BEACH, CALIFORNIA

APPROVALS	DATE
DRAWN CH	10-14-76
DESIGNED MF	10-19-76
APPROVED J.A.S.	10-19-76

REV	DESCRIPTION	DATE	APPROVED
B	REVISED & REDRAWN	10-14-76	CH
C	REMOVED ITEM NO'S 13 & 14, REVISED ITEM NO. 15	01-10-77	D.P.
D	SEE ECO 23820	03-16-78	CH
E	REMOVE NOTE 1 & ITEM NO. 25 FROM FACE OF P.W.G. & DELETED ITEM NO. 25 FROM PART LIST (ECO 6650)	01-11-85	G.N.
F	ON ADJUSTING SCREW CHART (100-300 PSI) 18.0 PSI WAS 18.0 PSI AND CHANGED CONFIGURATION OF ADJUSTING SCREW, SPRING & SPRING GUIDE ON 100-300 PSI DESIGN (ECO 7893)	11-26-85	G.N.
G	CORRECTED LOCATION OF ITEM 12, WAS POINTING TO ITEM 11 (ECO 9985)	10-24-88	JH
H	ADDED "RECOMMENDED SPARE PARTS" (NEE 49378)	03-16-05	PC
J	REDRAWN ON CAD (ECO 20320)	11-3-05	AK
K	ADDED 20-105 "PSI RANGE" TO TABULATION TABLE. (21467)	01-29-08	PC

1. SEE SHEET 2 FOR UL APPROVED DRAWING.

NOTES: UNLESS OTHERWISE SPECIFIED.

REV	DESCRIPTION	DATE	APPROVED
D	86184	90846	K



Pressure Relief Control

DESCRIPTION

The CRL Pressure Relief Control is a direct acting, spring loaded, diaphragm type relief valve. It may be used as a self-contained valve or as a pilot control for a Cla-Val Main valve. It opens and closes within very close pressure limits.

INSTALLATION

The CRL Pressure Relief Control may be installed in any position. The control body (7) has one inlet and one outlet port with a side pipe plug (24) at each port. These plugs are used for control connections or gauge applications. The inlet in the power unit body (6) is the sensing line port. A flow arrow is marked on the body casting.

OPERATION

The CRL Pressure Relief Control is normally held closed by the force of the compression spring above the diaphragm; control pressure is applied under the diaphragm.

When the controlling pressure exceeds the spring setting, the disc is lifted off its seat, permitting flow through the control.

When controlling pressure drops below spring setting, the spring returns the control to its normally closed position.

ADJUSTMENT PROCEDURE

The CRL Pressure Relief Control can be adjusted to provide a relief setting at any point within the range found on the nameplate.

Pressure adjustment is made by turning the adjustment screw (9) to vary the spring pressure on the diaphragm. Turning the adjustment screw clockwise increases the pressure required to open the valve. Counterclockwise decreases the pressure required to open the valve.

When pressure adjustments are complete the jam nut (10) should be tightened and the protective cap (1) replaced. If there is a problem of tampering, lock wire holes have been provided in cap and cover. Wire the cap to cover and secure with lead seal.

DISASSEMBLY

The CRL Pressure Relief Control does not need to be removed from the line for disassembly. Make sure that pressure shut down is accompanied prior to disassembly. If the CRL is removed from the line for disassembly be sure to use a soft jawed vise to hold body during work.

Refer to Parts List Drawing for Item Numbers.

1. Remove cap (1), loosen jam nut (10) and turn adjusting screw counterclockwise until spring tension is relieved.
2. Remove the eight screws (4) holding the cover (3) and powerunit body (6). Hold the cover and powerunit together and place on a suitable work surface.
See NOTE under REASSEMBLY.
3. Remove the cover (3) from powerunit body (6). The spring (12) and two spring guides (11).
4. Remove nut (13) from stem (19) and slide off the belleville washer (14), the upper diaphragm washer (15) and the diaphragm (16).
5. Pull the stem (19) with the disc retainer assembly (21) through the bottom of powerunit. The lower diaphragm washer (17) will slide off of stem top.
6. Remove jam nut (23) and disc retainer assembly (21) from stem. Use soft jawed pliers or vise to hold stem. The polished surface of stem must not be scored or scratched.
7. The seat (22) need not be removed unless it is damaged. If removal is necessary use proper size socket wrench and turn counterclockwise.

Note: Some models have an integral seat in the body (7).

INSPECTION

Inspect all parts for damage, or evidence of cross threading. Check diaphragm and disc retainer assembly for tears, abrasions or other damage. Check all metal parts for damage, corrosion or excessive wear.

REPAIR AND REPLACEMENT

Minor nicks and scratches may be polished out using 400 grit wet or dry sandpaper fine emery or crocus cloth. Replace all O-rings and any damaged parts.

When ordering replacement parts, be sure to specify parts list item number and all nameplate data.

REASSEMBLY

In general, reassembly is the reverse of disassembly. However, the following steps should be observed:

1. Lubricate the O-Ring (18) with a small amount of a good grade of waterproof grease, (Dow Corning 44 medium grade or equal). Use grease sparingly and install O-ring in powerunit body (6).
2. Install stem (19) in powerunit body (6). Use a rotating motion with minimum pressure to let stem pass through O-ring.
Do Not Cut O-Ring.
3. Install O-ring (5) at top of stem (19). Place lower diaphragm washer (17) on the stem with the serrated side up. Position diaphragm (16), upper diaphragm washer (15), with serration down, and belleville washer (14) with concave side down.
4. Position powerunit body (6) as shown on parts list drawing (top view).
5. Continue reassembly as outlined in disassembly steps 1 through 3.

Note: Item (4) Screw will have a quantity of 8 for the 0-75 and 20-200psi design and a quantity of 4 for the 100-300psi design. Item (25) Screw is used on the 100-300psi design only. Install item (25), before item (4) for preload of item (12) spring.

SYMPTOM	PROBABLE CAUSE	REMEDY
Fails to open.	Controlling pressure too low.	Back off adjusting screw until valve opens.
Fails to open with spring compression removed.	Mechanical obstruction, corrosion, scale build-up on stem.	Disassemble, locate, and remove obstruction, scale.
Leakage from cover vent hole when controlling pressure is applied.	Diaphragm Damage	Disassembly replace damaged diaphragm.
	Loose diaphragm assembly.	Tighten upper diaphragm washer.
Fails to close.	No spring compression.	Re-set pressure adjustment.
Fails to close with spring compressed.	Mechanical obstruction.	Disassemble, locate and remove obstruction.



1/2" & 3/4" PRESSURE RELIEF CONTROL

(Bronze Body with 303SS Trim)

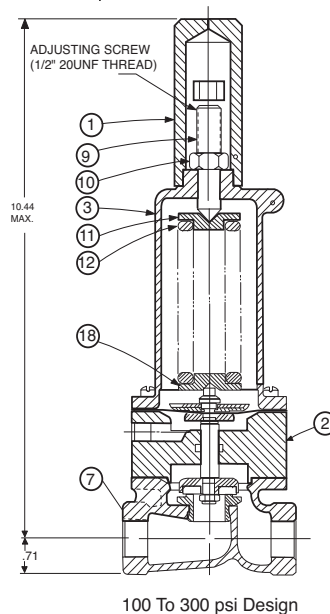
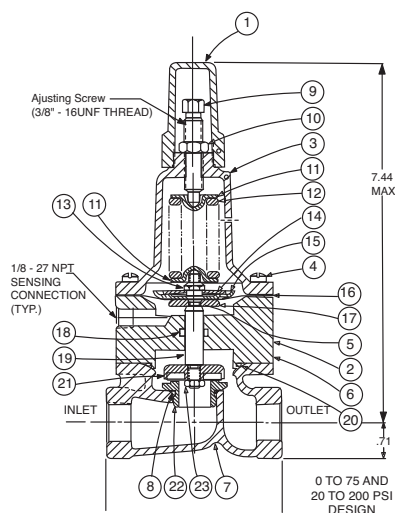
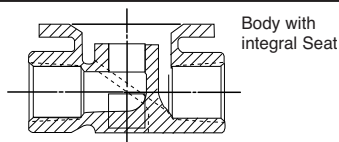
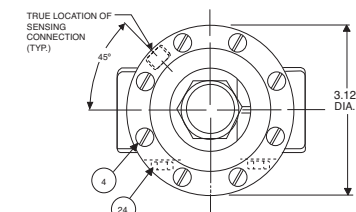

SIZE	SPRING	PART NUMBER
1/2"	0-75 PSI	7922201E
1/2"	20-105 PSI	7922205F
1/2"	20-200 PSI	7922202C
1/2"	100-300 PSI	8280901D
3/4"	0-75 PSI	7922901K
3/4"	20-105 PSI	7922903F
3/4"	20-200 PSI	7922902H
3/4"	100-300 PSI	8600501E

For 250-600 PSI Contact Factory

CRL Range PSI	APPROX. INCREASE FOR EACH CLOCKWISE TURN OF ADJUSTING SCREW
0 to 75	8.5 PSI
20 to 105	12.5 PSI
20 to 200	28.0 PSI
100 to 300	18.0 PSI

When ordering parts please specify:

1. All Nameplate Data
2. Item Part Number
3. Item Description

Item	Description	Material	Part Number			
			0-75	20-105	20-200	100-300
1	Cap	Plastic	67628J	67628J	67628J	1257601D
2	Nameplate	Brass	--	--	--	--
3	Cover	Bronze	C2544K	C2544K	C2544K	44587E
4*	Screw Fil. Hd. 10-32 x 1.88 (Qty 8)	303 SS	6757867E	6757867E	6757867E	6757867E
5*	O-Ring	Rubber	00902H	00902H	00902H	00902H
6	Body, Powerunit	Bronze	7920504D	7920504D	7920504D	7920504D
7	1/2" Body	Bronze	C7928K	C7928K	C7928K	C7928K
	3/4" Body	Bronze	C9083B	C9083B	C9083B	C9083B
8*	O-Ring, Seat	Rubber	00718H	00718H	00718H	00718H
9	Screw, Adjusting	Brass	7188201D	7188201D	7188201D	82811B
10	Nut Hex (Locking)	303 SS	6780106J	6780106J	6780106J	6780606H
11	Guide, Spring	303 SS	71881H	71881H	71881H	1630301J
12	Spring	CHR/VAN	71884B	20632101E	71885J	1630201A
13	Nut, Stem Upper	Bronze	73034B	73034B	73034B	73034B
14	Washer, Belleville	Steel	7055007E	7055007E	7055007E	7055007E
15	Washer, Diaphragm (upper)	303 SS	71891G	71891G	71891G	71891G
16*	Diaphragm	Rubber	C1505B	C1505B	C1505B	C1505B
17	Washer, Diaphragm (lower)	303 SS	45871B	45871B	45871B	45871B
18*	O-Ring, Stem	Rubber	00746J	00746J	00746J	00746J
19	Stem	303 SS	8982401F	8982401F	8982401F	8982401F
20*	O-Ring, Body	Rubber	00767E	00767E	00767E	00767E
21*	Retainer Assembly, Disc	303 SS	C9158B	C9158B	C9158B	C9158B
22	Seat	303Rub	62187A	62187A	62187A	62187A
23	Nut, Hex, Stem, Lower	Bronze	6779806G	6779806G	6779806G	6779806G
24	Pipe Plug	Bronze	6784701C	6784701C	6784701C	6784701C
	FACTORY SET POINT		50 PSI	60 PSI	60 PSI	100 PSI
	REPAIR KIT*		9170007A	9170007A	9170007A	9170007A

AK	07-10-08	AK	08-14-08	PC	10-1-2008	CLA-VAL CO. NEWPORT BEACH, CALIFORNIA	CATALOG NO.	DRAWING NO. 67783	REV BD								
	TYPE OF VALVE AND MAIN FEATURES						CK2 COCK/BALL VALVE										
							DESIGN	DRAWN	MGR	4-02-80							
								CHK'D	KD	4-03-80							
								APV'D	CH	4-07-80							
BB ADDED PN'S 67783-62B (NED 62200) BC ADDED PN'S 67783-63K (NED 62218) BD ADDED PN 67783-64H (NED 62446)						SCALE: NONE											
						FOR PN 67783-01K											
CLA-VAL PART NO. AND MATERIAL																	
BRONZE WITH HANDLE		STEEL WITH HANDLE		IRON WITH HANDLE		316 SST WITH HANDLE		316 SST W/ LOCKING HANDLE		BRONZE WITH HANDLE		MONEL WITH HANDLE		MONEL W/ LOCKING HANDLE		SIZE "NPT"	
67783-01K*		-09C		-17F		-25J SUPSD BY-26G				-41F SUPSD BY-01K						1/8"	
-02H		-10A		-18D		-26G		-51E SUPSD BY-26G -52C		-42D SUPSD BY-02H		-55F				1/4"	
-03F * -59H***		-11J		-19B		-27E		-46E SUPSD BY-27E -53A		-45G -57B**		-48A SUPSD BY-49J		-63K		3/8"	
-04D -60F***		-12G		-20K		-28C		-54J		-43B SUPSD BY-04D		-49J		-62B		1/2"	
-05A -61D***		-13E		-21H		-29A		-64H		-44K SUPSD BY-05A		-56D				3/4"	
-06J		-14C		-22F		-30J						-58K				1"	
-07G		-15K		-23D		-31G										1 1/4"	
-08E		-16H		-24B		-32E										1 1/2"	
-50G						-47C										2"	
* SEE ENGINEERING APPROVED VENDORS TABLE (SHEET 2 OF 2). ** HAMMOND VALVE 8501 ONLY. *** WILKINS CK2 (SEE SHEET 2 OF 2)																	

"THIS DRAWING IS THE PROPERTY OF CLA-VAL CO. AND SAME AND COPIES MADE THEREOF, IF ANY, SHALL BE RETURNED TO IT UPON DEMAND. DELIVERY AND DISCLOSURE HEREOF ARE SOLELY UPON CONDITION THAT THE SAME SHALL NOT BE USED, COPIED OR REPRODUCED, NOR SHALL THE SUBJECT HEREOF BE DISCLOSED IN ANY MANNER TO ANYONE FOR ANY PURPOSE, EXCEPT AS HEREIN AUTHORIZED, WITHOUT PRIOR WRITTEN APPROVAL OF CLA-VAL CO. THIS DRAWING IS SUBMITTED CONFIDENTIALLY AND MAY NOT BE USED IN THE MANUFACTURE OF ANY MATERIAL OR PRODUCT OTHER THAN SUCH MATERIALS AND PRODUCTS FURNISHED TO CLA-VAL CO. WHETHER OR NOT THE EQUIPMENT OR INFORMATION SHOWN HEREON IS PATENTED OR OTHERWISE PROTECTED, FULL TITLE AND COPYRIGHTS, IF ANY, IN AND TO THIS DRAWING AND/OR INFORMATION DELIVERED OR SUBMITTED ARE FULLY RESERVED CLA-VAL CO."



— MODEL — **X46**

Flow Clean Strainer



X46A Straight

- Self Scrubbing Cleaning Action
- Straight Type or Angle Type

The Cla-Val Model X46 Strainer is designed to prevent passage of foreign particles larger than .015". It is especially effective against such contaminant as algae, mud, scale, wood pulp, moss, and root fibers. There is a model for every Cla-Val. valve.

X46B Angle



The X46 Flow Clean strainer operates on a velocity principle utilizing the circular "air foil" section to make it self cleaning. Impingement of particles is on the "leading edge" only. The low pressure area on the downstream side of the screen prevents foreign particles from clogging the screen. There is also a scouring action, due to eddy currents, which keeps most of the screen area clean.

Dimensions (In Inches)

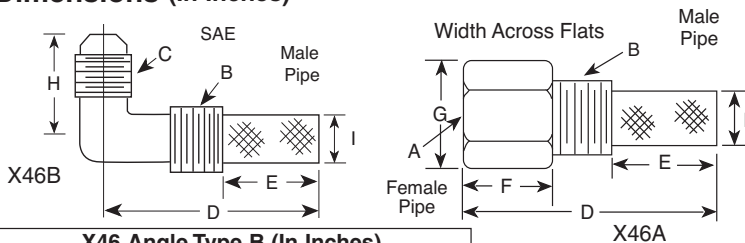

B(NPT)	C(SAE)	D	E	H	I
1/8	1/4	1-3/8	5/8	7/8	1/4
1/4	1/4	1-3/4	3/4	1	3/8
3/8	1/4	2	7/8	1	1/2
3/8	3/8	1-7/8	7/8	1	1/2
1/2	3/8	2-3/8	1	1-1/4	5/8

A (NPT)	B (NPT)	D	E	F	G	I
1/8	1/8	1-3/4	3/4	1/2	1/2	1/4
1/4	1/4	2-1/4	1	3/4	3/4	3/8
3/8	3/8	2-1/2	1	7/8	7/8	1/2
3/8	1/2	2-1/2	1-1/4	1/2	7/8	3/4
1/2	1/2	3	1-1/4	1	1-1/8	3/4
3/8	3/4	3-3/8	2	1/2	1	7/8
3/4	3/4	4	2	1	1-1/2	7/8
3/8	1	4-1/4	2-3/4	1/2	1-3/8	7/8
1	1	4-1/2	2-3/4	1-1/4	1-3/4	7/8
1/2	1	4-1/4	2-3/4	1/2	1-3/8	7/8

When Ordering, Please Specify:

- Catalog Number X46
- Straight Type or Angle Type
- Size Inserted Into and Size Connection
- Materials

INSTALLATION

The strainer is designed for use in conjunction with a Cla-Val Main Valve, but can be installed in any piping system where there is a moving fluid stream to keep it clean. When it is used with the Cla-Val Valve, it is threaded into the upstream body port provided for it on the side of the valve. It projects through the side of the Main Valve into the flow stream. All liquid shunted to the pilot control system and to the cover chamber of the Main Valve passes through the X46 Flow Clean Strainer.

INSPECTION

Inspect internal and external threads for damage or evidence of cross-threading. Check inner and outer screens for clogging, embedded foreign particles, breaks, cracks, corrosion, fatigue, and other signs of damage.

DISASSEMBLY

Do not attempt to remove the screens from the strainer housing.

CLEANING

After inspection, cleaning of the X46 can begin. Water service usually will produce mineral or lime deposits on metal parts in contact with water. These deposits can be cleaned by dipping X46 in a 5-percent muriatic acid solution just long enough for deposit to dissolve. This will remove most of the common types of deposits.

Caution: use extreme care when handling acid. If the deposit is not removed by acid, then a fine grit (400) wet or dry sandpaper can be used with water. Rinse parts in water before handling. An appropriate solvent can clean parts used in fueling service. Dry with compressed air or a clean, lint-free cloth. Protect from damage and dust until reassembled.

REPLACEMENT

If there is any sign of damage, or if there is the slightest doubt that the Model X46 Flow Clean Strainer may not afford completely satisfactory operation, replace it. Use Inspection steps as a guide. Neither inner screen, outer screen, nor housing is furnished as a replacement part. Replace Model X46 Flow Clean Strainer as a complete unit.

When ordering replacement Flow-Clean Strainers, it is important to determine pipe size of the tapped hole into which the strainer will be inserted (refer to column A or F), and the size of the external connection (refer to column B or G).



—MODEL— **CV**
Flow Control

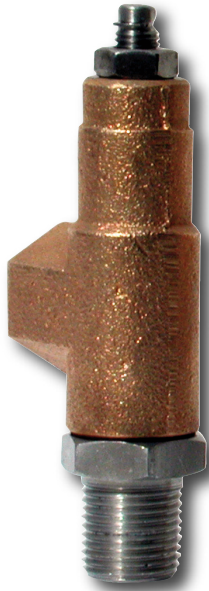

DESCRIPTION

The CV Control is an adjustable restriction which acts as a needle valve when flow is in the direction of the stem. When flow is in the reverse direction, the port area opens fully to allow unrestricted flow. When installed in the control system of a Cla-Val automatic valve, it can be arranged to function as either an opening or closing speed control.

OPERATION

The CV Flow Control permits full flow from port A to B, and restricted flow in the reverse direction. Flow from port A to B lifts the disc from seat, permitting full flow. Flow in the reverse direction seats the disc, causing fluid to pass through the clearance between the stem and the disc. This clearance can be increased, thereby increasing the restricted flow, by screwing the stem out, or counter-clockwise. Turning the stem in, or clockwise reduces the clearance between the stem and the disc, thereby reducing the restricted flow.'

INSTALLATION

Install the CV Flow Control as shown in the valve schematic. All connections must be tight to prevent leakage.

DISASSEMBLY

Follow the sequence of the item numbers assigned to the parts in the cross sectional illustration for recommended order of disassembly.

Use a scriber, or similar sharp-pointed tool to remove O-ring from the stem.

INSPECTION

Inspect all threads for damage or evidence of cross-threading. Check mating surface of seat and valve disc for excessive scoring or embedded foreign particles. Check spring for visible distortion, cracks and breaks. Inspect all parts for damage, corrosion and cleanliness.

CLEANING

After disassembly and inspection, cleaning of the parts can begin. Water service usually will produce mineral or lime deposits on metal parts in contact with water. These deposits can be cleaned by dipping the parts in a 5-percent muriatic acid solution just long enough for deposits to dissolve. This will remove most of the common types of deposits. **Caution: use extreme care when handling acid.** If the deposit is not removed by acid, then a fine grit (400) wet or dry sandpaper can be used with water. Rinse parts in water before handling. An appropriate solvent can clean parts used in fueling service. Dry with compressed air or a clean, lint-free cloth. Protect from damage and dust until reassembled.

REPAIR AND REPLACEMENT

Minor nicks and scratches may be polished out using a fine grade of emery or crocus cloth; replace parts if scratches cannot be removed.

Replace O-ring packing and gasket each time CV Flow Control is overhauled.

Replace all parts which are defective. Replace any parts which create the slightest doubt that they will not afford completely satisfactory operation. Use Inspection steps as a guide.

REASSEMBLY

Reassembly is the reverse of disassembly; no special tools are required.

TEST PROCEDURE

No testing of the flow Control is required prior to reassembly to the pilot control system on Cla-Val Main Valve.



CV

3/8" Flow Control

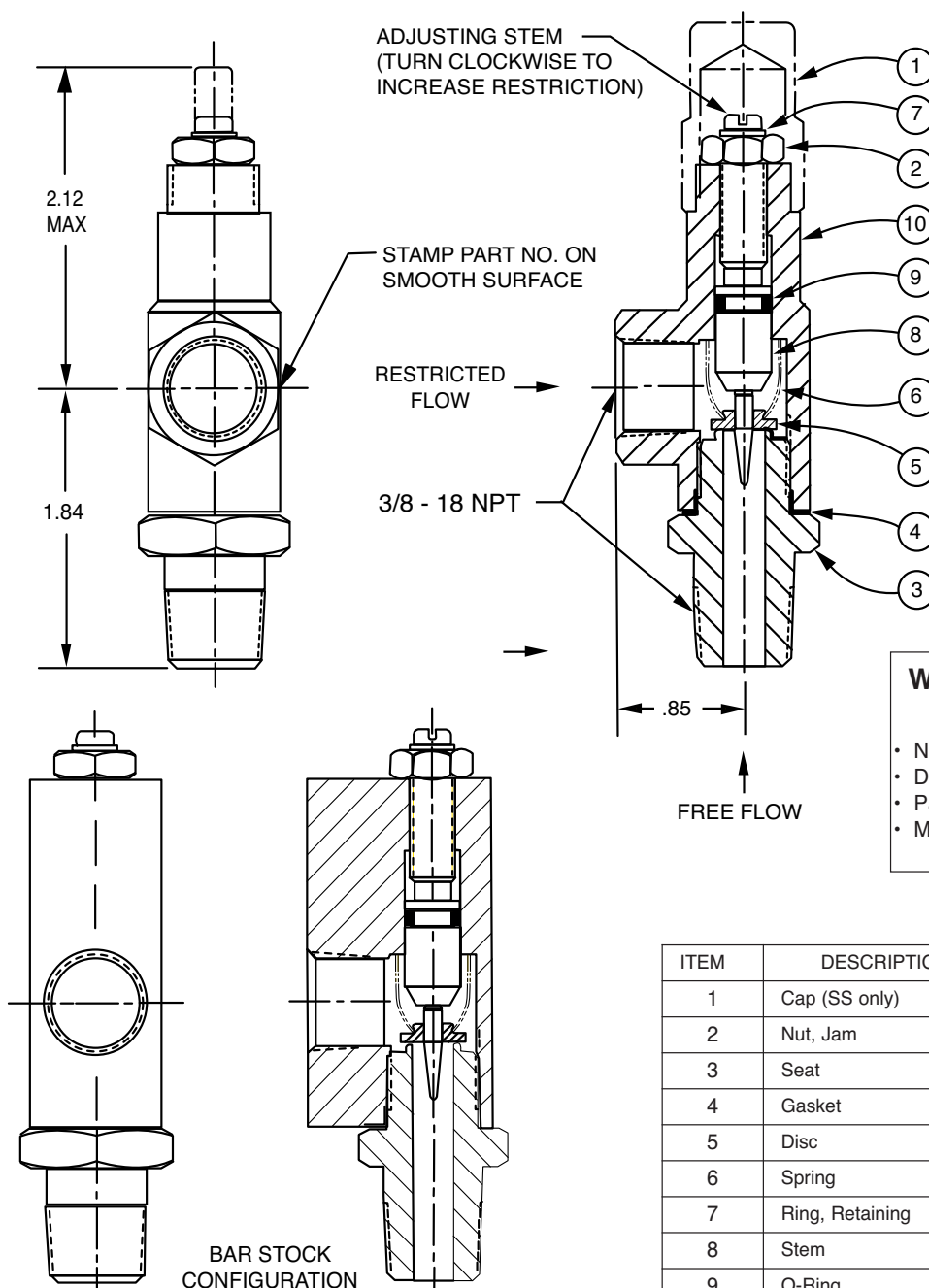
**When ordering parts,
please specify:**

- Number Stamped on Side
- Description (CV Flow Control)
- Part Description
- Material

ITEM	DESCRIPTION	QTY
1	Cap (SS only)	1
2	Nut, Jam	1
3	Seat	1
4	Gasket	1
5	Disc	1
6	Spring	1
7	Ring, Retaining	1
8	Stem	1
9	O-Ring	1
10	Housing	1

—MODEL— **CDC-1**

Check Valve (Sizes 3/8" and 1/2")



- NSF 61 Approved
- Meets low lead requirements
- Soft Seat for Bubble Tight Shutoff, Spring Loaded for Fast Seating Action
- Compact Design
- Low Cracking Pressure 1/2 psi
- Flow Profile Designed to Minimize Head Loss
- Perfect Seating both at High and Low Pressure, Wide Temperature Range: +10° to 210°F
- Polyetherimide Disc to ensure the Best Resistance for Corrosion and Abrasion
- Patented Disc Guide to Prevent Any Side Loading

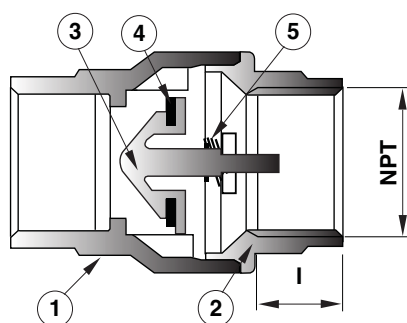

Full Open Operation

Item	Description	Material
1	Body	Brass
2	End Connection	Brass
3	Disc	Polyetherimide
4	Seat	NBR
5	Spring	Stainless Steel

Available only in replacement assembly.

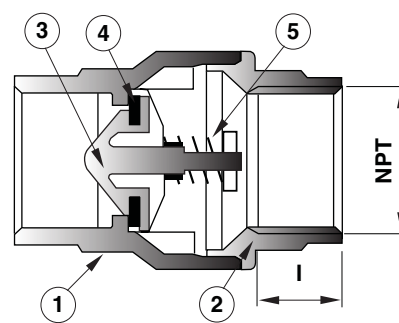

Tight Closing Operation

Dimensions

Size (NPT)	Stock Number	A	B	C	I	C _v	psi	Wt.
3/8"	9834501A	1.73	0.79	1.06	0.40	4.55	400	0.37
1/2"	9834502J	2.32	0.98	1.35	0.53	6.00	400	0.32

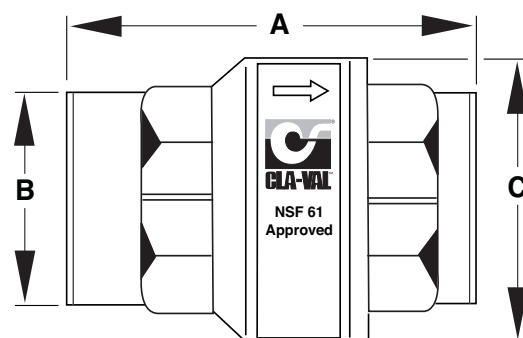



X43 Strainer

ITEM	DESCRIPTION	MATERIAL
1	Pipe Plug	Steel
2	Strainer Plug	Brass
3	Gasket	Copper
4	Screen	SST
5	Body	Brass

No parts available. Replacement assembly only.

Standard 60 mesh pilot system strainer for fluid service.

Size	Stock Number
3/8 x 3/8	33450J

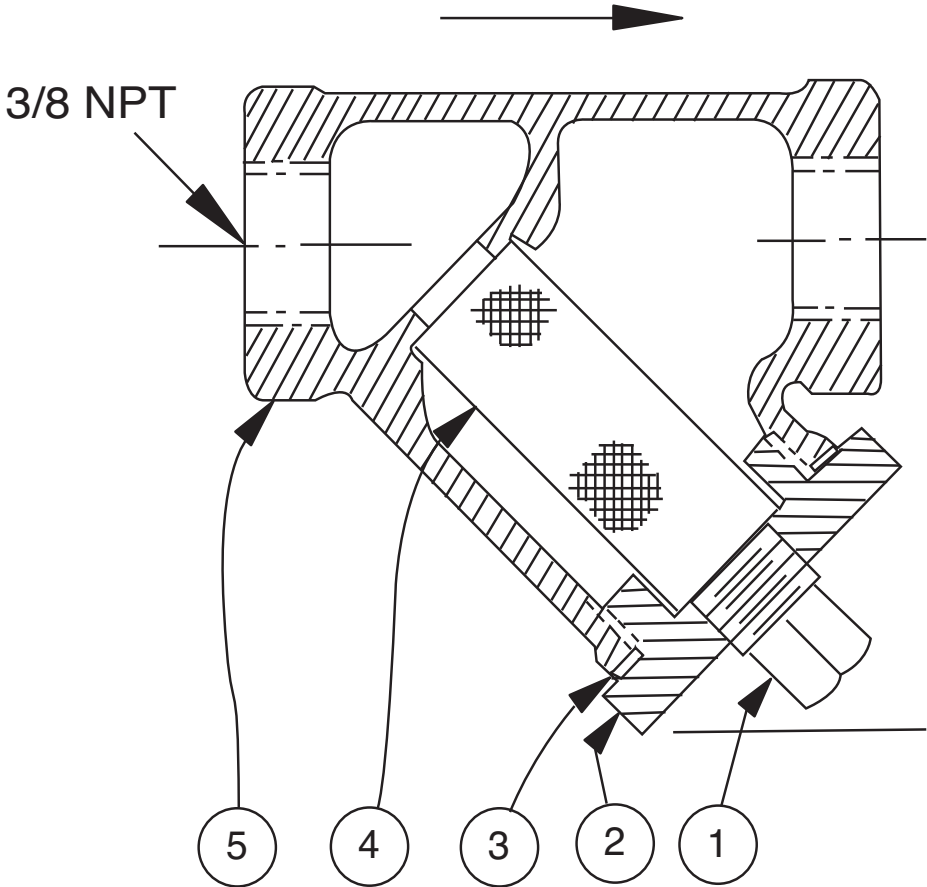



—MODEL— **REPAIR KITS**

Model 100-01 Hytrol Main Valve

BUNA-N MATERIAL				
	RUBBER KIT	REPAIR KIT	REBUILD KIT	STUD & NUT KIT
	STOCK NO.	STOCK NO.	STOCK NO.	STOCK NO.
3/8"	9169801K		21176614B	21176633J
1/2"	9169802H	21176602F	21176615A	21176634H
3/4"	9169802H	21176602F	21176615A	21176634H
1" Non-Guided	9169803F	21176601G	21176616K	21176636F
1"	9169804D	21176603E	21176617J	21176636F
1 1/4"	9169804D	21176603E	21176617J	21176636F
1 1/2"	9169804D	21176603E	21176617J	21176636F
2"	9169805A	21176608K	21176618H	21176637E
2 1/2"	9169811J	21176609J	21176619G	21176638D
3"	9169812G	21176604D	21176620D	21176639C
4"	9169813E	21176605C	21176621C	21176640K
6"	9169815K	21176606B	21176622B	21176641J
8"	9817901D	21176607A	21176623A	21176642H
10"	9817902B	21176610F	21176624K	21176643G
12"	9817903K	21176611E	21176625J	21176644F
14"	9817904H	21176612D	21176626H	21176645E
16"	9817905E	21176613C	21176627G	21176645E

Model 100-20 Hytrol Main Valve

BUNA-N MATERIAL				
	RUBBER KIT	REPAIR KIT	REBUILD KIT	STUD & NUT KIT
	STOCK NO.	STOCK NO.	STOCK NO.	STOCK NO.
3"	9169805A	21176608K	21176618H	21176637E
4"	9169812G	21176604D	21176620D	21176639C
6"	9169813E	21176605C	21176621C	21176640K
8"	9169815K	21176606B	21176622B	21176641J
10"	9817901D	21176607A	21176623A	21176642H
12"	9817902B	21176610F	21176624K	21176643G
14"	9817903K	21176611E	21176625J	21176644F
16"	9817903K	21176611E	21176625J	21176644F

Consult factory for larger sizes

Rubber Kit Includes: Diaphragm, Disc, Spacer Washers

Repair Kit Includes: Diaphragm, Disc, Spacer Washers, Epoxy Coated Disc Retainer, Epoxy Coated Diaphragm Washer, Protective Washer

Rebuild Kit Includes: Diaphragm, Disc, Spacer Washers, Epoxy Coated Disc Retainer, Epoxy Coated Diaphragm Washer, Protective Washer, Stainless Steel Bolts & Washers (6" & Below), Stainless Steel Studs, Nuts, & Washers (8" & Above), Stem, Stem Nut, Disc Guide

Stud & Nut Kit Includes: Stainless Steel Bolts & Washers (6" & Below), Stainless Steel Studs, Nuts, & Washers (8" & Above)

Repair Kits for 100-02/100-21 Powertrol and 100-03/100-22 Powercheck Main Valves

For: Powertrol and Powercheck Main Valves—150 Pressure Class Only

Includes: Diaphragm, Disc (or Disc Assembly) and O-rings and full set of spare Spacer Washers.

Valve Size	Kit Stock Number 100-02	Valve Size	Kit Stock Number	
			100-02 & 100-03	100-21 & 100-22
3/8"	9169901H	2 1/2"	9169910J	N/A
1/2" & 3/4"	9169902F	3"	9169911G	9169905J
1"	9169903D	4"	9169912E	9169911G
1 1/4" & 1 1/2"	9169904B	6"	9169913C	9169912E
2"	9169905J	8"	99116G	9169913C
		10"	9169939H	99116G
		12"	9169937B	9169939H

Larger Sizes: Consult Factory.

Repair Kits for 100-04/100-23 Hy-Check Main Valves

For: Hy-Check Main Valves—150 Pressure Class Only

Includes: Diaphragm, Disc and O-Rings and full set of spare Spacer Washers.

Valve Size	Kit Stock Number		Valve Size	Kit Stock Number	
	100-04	100-23		100-04	100-23
4"	20210901B	N/A	12"	20210905H	20210904J
6"	20210902A	20210901B	14"	20210906G	N/A
8"	20210903K	20210902A	16"	20210907F	20210905H
10"	20210904J	20210903K	20"	N/A	20210907F
			24"	N/A	20210907F

Larger Sizes: Consult Factory.

Repair Kits for Pilot Control Valves (In Standard Materials Only)

Includes: Diaphragm, Disc (or Disc Assembly), O-Rings, Gaskets or spare Screws as appropriate.

BUNA-N® (Standard Material)				VITON (For KB Controls)	
Pilot Control	Kit Stock Number	Pilot Control	Kit Stock Number	Pilot Control	Kit Stock Number
CDB	9170006C	CFM-9	12223E	CDB-KB	9170012A
CDB-30	9170023H	CRA (w/bucking spring)	9170001D	CRA-KB	N/A
CDB-31	9170024F	CRD (w/bucking spring)	9170002B	CRD-KB (w/bucking spring)	9170008J
CDB-7	9170017K	CRD (no bucking spring)	9170003K	CRL-KB	9170013J
CDH-2	18225D	CRD-18	20275401K	CDHS-2BKB	9170010E
CDHS-2	44607A	CRD-22	98923G	CDHS-2FKB	9170011C
CDHS-2B	9170004H	CRL (55F, 55L)	9170007A	CDHS-18KB (no bucking spring)	9170009G
CDHS-2F	9170005E	CRL60/55L-60	9170033G	102C-KB	1726202D
CDHS-3C-A2	24657K	CRL60/55L60 1"	9170042H		
CDHS-8A	2666901A	CRL-4A	43413E		
CDHS-18	9170003K	CRL-5 (55B)	65755B		
CDS-4	9170014G	CRL-5A (55G)	20666E		
CDS-5	14200A	CRL-18	20309801C		
CDS-6	20119301A	Universal CRL	9170041K		
CDS-6A	20349401C	CV	9170019F		
CFCM-M1	1222301C	X105L (O-ring)	00951E	Buna-N®	
CFM-2	12223E	102B-1	1502201F		
CFM-7	1263901K	102C-2	1726201F	CRD Disc Ret. (Solid)	C5256H
CFM-7A	1263901K	102C-3	1726201F	CRD Disc Ret. (Spring)	C5255K

Repair Assemblies (In Standard Materials Only)

Control	Description	Stock Number
CF1-C1	Pilot Assembly Only	89541H
CF1-CI	Complete Float Control less Ball and Rod	89016A
CFC2-C1	Disc, Distributor and Seals	2674701E
CSM 11-A2-2	Mechanical Parts Assembly	97544B
CSM 11-A2-2	Pilot Assembly Only	18053K
33A 1"	Complete Internal Assembly and Seal	2036030B
33A 2"	Complete Internal Assembly and Seal	2040830J

When ordering, please give complete nameplate data of the valve and/or control being repaired. MINIMUM ORDER CHARGE APPLIES

CLA-VAL

1701 Placentia Ave • Costa Mesa CA 92627 Phone: 949-722-4800 • Fax: 949-548-5441 • E-mail: info@cla-val.com • www.cla-val.com

© Copyright Cla-Val 2018 Printed in USA Specifications subject to change without notice.

N-RK (R-08/2018)